

VIO Series

INDEX

Introducing the series	4
Line Array Systems.....	6
VIO L212.....	8
VIO L1610	14
VIO L210.....	20
VIO L1608	26
VIO L208.....	32
Subwoofers.....	38
VIO S218	40
VIO S218F	40
VIO S318	46
VIO S118R.....	50
VIO S118	50
VIO S115	54
Constant Curvature Array Speakers.....	56
VIO C12	58
VIO C15	58
VIO C212	58
Point-Source Speakers	64
VIO X10.....	66
VIO X12.....	66
VIO X15.....	66
VIO X310	70
VIO X315	70
VIO X206	74
VIO X205	80
Wedges	82
VIO W15T.....	84
VIO W12T.....	88
VIO W10.....	92
Technologies	94
Power Box.....	96
AC 26N	97
Softwares.....	98
References	100

INTRODUCING VIO SERIES

Throughout its history, dBTechnologies has set new standards in the professional audio industry, bringing the benefits of fully-powered systems and line array technology to a much wider range of users.

With VIO, dBTechnologies took a step forward, providing a complete range of powered sound reinforcement solutions able to face smoothly any professional production requirement.

Encompassing line array systems, subwoofers, point-source speakers, arrayable systems, and stage monitors, VIO range provides solutions for the most demanding tour stages and installed PAs in venues of any kind and size.

Freshly designed wooden cabinets, premium components, clever acoustic design solutions, last generation amplifying technology, cutting-edge DSP programming. All of this comes together to deliver imposing sound pressure levels, outstanding dispersion control and a detailed, clear-cut audio performance.

Aside from complete networkability, enabling every cabinet of the range to complete remote monitoring and real-time control via dBTechnologies' software Aurora Net, each VIO system has been designed keeping in mind ease of rigging and installation, as well as acoustic compatibility, allowing users to smoothly design and set up countless sound reinforcement solutions.

**SMARTER
LIGHTER
FASTER
STRONGER**



LINE ARRAY SYSTEMS

Since the early 2000s, dBTechnologies has set new standards in the sound reinforcement industry, bringing line array technology to a much wider range of users.

With VIO series, the Italian manufacturer steps up to the next level, making the most of its know-how and experience in design, acoustic efficiency and DSP programming, while keeping an eye on ease of use. Now VIO line array family encompasses a complete range of systems, designed to fit a variety of applications, from touring to fixed installation, as well as venues of any size and scope.



VIO L212



3-WAY ACTIVE LINE ARRAY SYSTEM

3200W RMS DIGIPRO G4 AMP TECHNOLOGY

FULL RANGE SMPS WITH PFC

HORN-LOADED MIDRANGE FOR IMPROVED ACOUSTIC EFFICIENCY AND COVERAGE ACCURACY

EXCLUSIVELY DESIGNED WAVEGUIDE FOR MAXIMUM HF DIRECTIVITY CONTROL

ADVANCED DSP FEATURING LINEAR PHASE FIR FILTERS

ACOUSTIC COMPATIBILITY WITH VIO L210 USED AS DOWN-FILL

MODULAR SLOT FOR NETWORK AND DIGITAL AUDIO EXPANSION CARDS - RDNET CARD INSTALLED

NFC™ + FRONT LED IDENTIFICATION SYSTEM

SYSTEM TEST FOR QUICK TRANSDUCERS DIAGNOSTICS

IPOS INTELLIGENT POWER-ON SEQUENCE

RUBBER MAGNETIC RAINCOVER INCLUDED

ONLY 54.4 KG PER MODULE

BUILT-IN INCLINOMETER

LARGE FORMAT LINE ARRAY MODULE

VIO L212 is the first dBTechnologies' full scale line array module designed for large touring sound reinforcement applications, concurrently providing mighty output capability, optimized coverage behaviour, alongside with rapid and easily configurable rigging solutions, one of the most compact and lightest active 2x12" line array systems.

Speaker Type	3-Way Active Line Array Module
Usable Bandwidth [-10dB]	49.8 - 20,000 Hz
Frequency Response [-6dB]	55 - 18,600 Hz
Max SPL	One Unit: 142 dB
HF	2x 1.4", 3" v.c. - Neodymium
MF	4x 6.5", 2" v.c. - Neodymium
LF	2x 12", 3" v.c. - Neodymium
Horizontal Directivity	90°
Vertical Directivity	depends on array size and configuration
Amplifier	3200 W RMS [2x 1600 W RMS Class-D Digipro® G4]
Cooling	Convection, Internal fan
Power Supply	Full-range SMPS with PFC (100V--240V-, 50-60Hz)
Controller	DSP 32 bit
AD/DA Converter	24 bit/96 kHz
Limiter	Dual Active Multiband Peak, RMS, Thermal
Processing (filters)	FIR Linear phase
Signal Input	1x XLR female, balanced 1x USB Data Service
Signal Output	1x XLR male, balanced
Power Socket	1x PowerCON TRUE1 In 1x PowerCON TRUE1 Out
Expansion card	RDNet Card (1x RJ45 IN 1x RJ45 Link) Dante Card [Optional]
Controls	1x Speaker Coupling (7 presets) 1x High pass filter Rotary Encoder (8 presets) 1x HF Compensation (8 presets) 1x System Test Button
Special Features	NFC™ and Frontal LED Identification System 380V Resistant SMPS IPOS Intelligent Power-On Sequence Opto-isolated floating pre-amp System Test (transducers diagnostics) Inclinometer
Housing	Multiplex plywood - Polyurea painting
Handles	4x handles (2 on each side)
Rain cover	Included [Rubber magnetic]
Rigging Points	3 points rigging hardware
Width x Height x Depth	1100 x 380 x 450 mm (43.31 x 14.96 x 17.72 in)
Weight	54.4 kg (119.93 lbs)

3-WAY LINE ARRAY



PREMIUM COMPONENTS SEALED IN A UNIQUE ACOUSTIC DESIGN

2x12" neodymium woofers (3" v.c.) placed to the outsides in a dipolar arrangement provide an accurate transient response and an extended and controlled low-end reproduction.

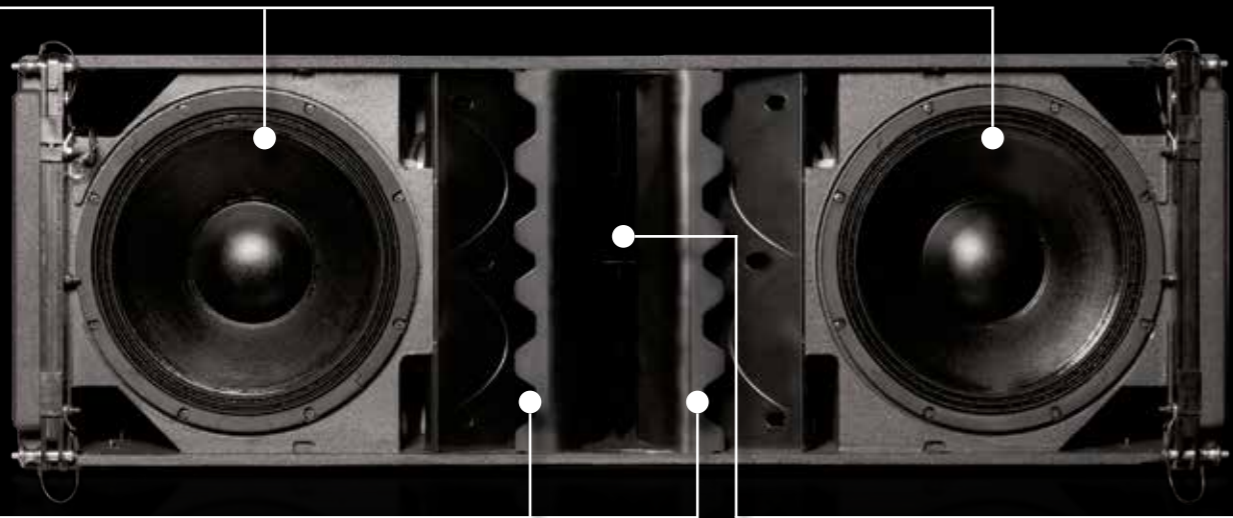

ACOUSTIC EFFICIENCY

The mid-range section is mounted in the center of the cabinet in a horn-loaded configuration which dramatically contributes to the system's acoustic efficiency. Midrange frequencies are delivered by 4x 6.5" neodymium woofers (voice coil 2").

THE WAVEGUIDE

The 2x 1.4" neodymium compression drivers (voice coil 3") have been mounted to a waveguide which contributes to create a cylindrical wavefront, much to the advantage of the system's intelligibility and throw capabilities.

CLASS-D AMPLIFIER WITH FULL-RANGE POWER SUPPLY AND PFC

Each VIO L212 acoustic engine is driven by 2 Digipro G4® Class-D 1600W amplifiers, providing each system with a total of 3200W RMS. The switched mode power supply is equipped with PFC (Power Factor Corrector) which greatly improves the efficiency of the system. Performances of the amplifier are very stable and consistent, regardless of the quality of the mains and fluctuations. This also grants a worldwide compatibility of the power supply (from 100V to 240V 50/60Hz) and limits power consumption. Furthermore, the power supply is 380V resistant, so the final amplifiers will be switched off in case of an undesired strike of 380V current, saving them from any damage.



ADVANCED PRE-AMPLIFIER

The amp allows users to run system-test on electronics and transducers before and after use and a real time impedance control.

The preamplifier's floating audio input design grants a digital optical isolation between earth ground from the mains and the audio ground flowing into the preamplifier board. This galvanic isolation greatly improves resistance to interferences and any unwanted buzzing and noises.

The USB port allows firmware upgrades, while diagnostics analysis, and real time monitoring on system performances and failures are available on Aurora Net software.

IPOS TECHNOLOGY

Exclusive technology of VIO L212 amplifier is IPOS (Intelligent Power-On Sequence), a circuit that controls the sequence in which the main power supplies of all units within an array ramp up. As a result, each module is switched on in a different time frame, keeping the overall system's inrush current low, even in very big PA system deployments.

TRANSPORT & INSTALLATION ACCESSORIES

DRK-212	TF-VI02	DT-VI0L212	DTT-VI0L212	DO-VI0L212	DT-DRK212	EFK-1	TC-VI0L212
Flybar for VIO L212. For flown and groundstacked configurations.	Transition frame for flying VIO L210 under VIO L212.	Touring cart for 4 VIO L212 modules. [EFK-1 accessory for stack configurations not included].	Wooden cover top for DT-VIO L212.	Dolly transport for one VIO L212.	Touring cart for two DRK-212 flybars and cables storage.	Extension feet kit for stack configuration on DT-VI0L212.	Transport cover for 4 VIO L212 on DT-VI0L212. Waterproof

CABLES

DAC-100	XLR-XLR audio cable (100 cm).
DAC-500	XLR-XLR audio cable (500 cm).
DPTC-100L	PowerCON TRUE1-PowerCON TRUE1 power link cable (100cm).
DPTC-1000M	Mains PowerCON TRUE1 cable (10m). Different plugs available for several countries.
DPTC-2000M	Mains PowerCON TRUE1 cable (20m). 16A CekON.
RDC-45F	RJ45 to XLR 3 poles female conversion cable, 6 cm length. The cable converts from RDNet RJ45 to XLRf.
RDC-45M	RJ45 to XLR 3 poles male conversion cable, 6 cm length. The cable converts from RDNet RJ45 to XLRm.
RJ45-RJ45-150	RJ45-RJ45 link cable (150cm) for RDNet speakers. EtherCON connectors.
RJ45-RJ45-75	RJ45-RJ45 link cable (75cm) for RDNet speakers. EtherCON connectors.
CAT6-CAT6-100	CAT6-CAT6 link cable (100cm) for DANTE™ AoIP and RDNet. EtherCON connectors.
CAT6-CAT6-170	CAT6-CAT6 link cable (170cm) for DANTE™ AoIP and RDNet. EtherCON connectors.
CAT6-CAT6-500	CAT6-CAT6 link cable (500cm) for DANTE™ AoIP and RDNet. EtherCON connectors.

UNPAIRED SOUND QUALITY

AUDINATE DANTETM READY

The preamplifier is equipped with a modular slot for expansion cards. As a default, VIO L212 is equipped with dBTechnologies RD-Net card, for real time remote control via **Aurora Net** software.

Furthermore, the preamplifier is ready for future upgrades with Audinate Dante™ AoIP protocol. To help users in this configuration, VIO L212 comes with built-in technologies: **Near Field Communication (NFC™)** proximity sensors are used to determine the position of each box within an array.

This technology, together with a hi-brightness LED bulb on the front of the enclosure, contributes to help the user to recognize, identify and match each box physical position on the remote control software Aurora Net.

TOUR GRADE ENCLOSURE

Built in plywood reinforced with a black polyurea finish, the cabinet features 2 handles per side and a magnetic raincover to protect the amp module. The overall weight of a single module is limited to only 54.4. Kg (119.93 lbs), which simplifies, speeds up and cuts set up and transport costs.



SMART RIGGING AND FULL COMPATIBILITY WITH VIO L210 AND VIO L1610

Just like smaller systems in the VIO family, L212 comes with VIO's peculiar 3-point rigging system allowing a smooth and fast set up of the system. The 2 front links easily connect the modules from every angle. The back central rigging strand is equipped with a hook type link to set the relative splay angles determined via prediction software ranging from 0.5° to 8°. While lifting up the array, the rigging strand will automatically block the systems at the preset angles with no heavy lifting required.

A precise resolution starting from 0.5° steps helps to get smooth aiming at long distances.

Splay angles can be set directly in the dedicated transport cart DT-VIOL212 which houses 4 modules. The same cart also acts as a solid base in case of stacked configurations thanks to accessory feet kit EFK-1.



A single-module wheel-board DO-VIOL212 is also available to ease transport of single cabinets.

The dedicated flying frame DRK-212 features 2 hooks facilitating precise inclination of the array both for positive or negative angles. DT-DRK212 is the dedicated cart allowing to transport and store 2 flying frames and several cables.

TF-VIO2 adaptor allows to rig VIO L210 as down-fill cabinets under VIO L212 arrays in order to create perfectly compatible hybrid systems.



VIO L1610



3-WAY ACTIVE LINE ARRAY SYSTEM

1600W RMS DIGIPRO G4 AMP TECHNOLOGY

FULL RANGE SMPS WITH PFC

STATE-OF-THE-ART 3-WAY SYMMETRIC ACOUSTIC DESIGN

COAXIAL MF + HF COMPRESSION DRIVER MOUNTED ON WAVEGUIDE

LOW LATENCY DSP FEATURING LINEAR PHASE FIR FILTERS

STANDALONE OR DOWNFILL FOR VIO L212 SYSTEMS

MODULAR SLOT FOR NETWORK AND DIGITAL AUDIO EXPANSION CARDS (RDNET CARD INSTALLED)

NFC™ + FRONT LED IDENTIFICATION SYSTEM

SYSTEM TEST FOR QUICK TRANSDUCERS DIAGNOSTICS

INTEGRATED 3-POINT SMART RIGGING SYSTEM

RUBBER MAGNETIC RAINCOVER INCLUDED

LINE ARRAY MODULE

VIO L1610 embodies the natural evolution of the VIO family. A game-changing 3-way active line array system, created to combine the stellar audio performance of VIO L212 with the compact size of VIO L210.

Delivering astonishing power and impressive SPLs, along with the most consistent audio performance, VIO L1610 makes the most of its 3-way design, ensuring outstanding dynamics and definition.

Speaker Type	3-Way Active Line Array Module
Usable Bandwidth [-10dB]	56 - 20,000 Hz
Frequency Response [-6dB]	60 - 17,000 Hz
Max SPL	One Unit: 141 dB
HF- MF	1x 1.4", 4"-2.5" v.c. - Coaxial Neodymium
LF	2x 10", 2.5" v.c. - Neodymium
Horizontal Directivity	100°
Vertical Directivity	depends on array size and configuration
Amplifier	1600 W RMS Class-D Digipro® G4
Cooling	Convection, Internal fan
Power Supply	Full-range SMPS with PFC (100V--240V-, 50-60Hz)
Signal Input	1x XLR female, balanced 1x USB Data Service
Signal Output	1x XLR male, balanced
Power Socket	1x PowerCON TRUE1 In 1x PowerCON TRUE1 Out
Expansion card	RNet Card (1x RJ45 IN 1x RJ45 Link) Dante Card [Optional]
Controls	1x Speaker Coupling (8 presets) 1x High pass filter Rotary Encoder (8 presets) 1x HF Compensation (8 presets) 1x System Test Button
Special Features	NFC™ and Frontal LED Identification System 380V Resistant SMPS IPOS Intelligent Power-On Sequence Opto-isolated floating pre-amp System Test (transducers diagnostics) Inclinometer
Housing	Multiplex plywood - Polyurea painting
Handles	1x Side, 2 on back
Rain cover	Included [Rubber magnetic]
Rigging Points	3 points rigging hardware
Width x Height x Depth	720 x 320 x 520 mm (28.35 x 12.60 x 20.47 in)
Weight	31.3 kg (69 lbs)

3-WAY LINE ARRAY



SYMMETRIC COAXIAL DESIGN

2x10" woofers providing an extended LF reproduction interact with a custom coaxial transducer which encloses the high-frequency driver and the mid-range driver in a single coaxial component - 4" MF plus 2.5" HF.

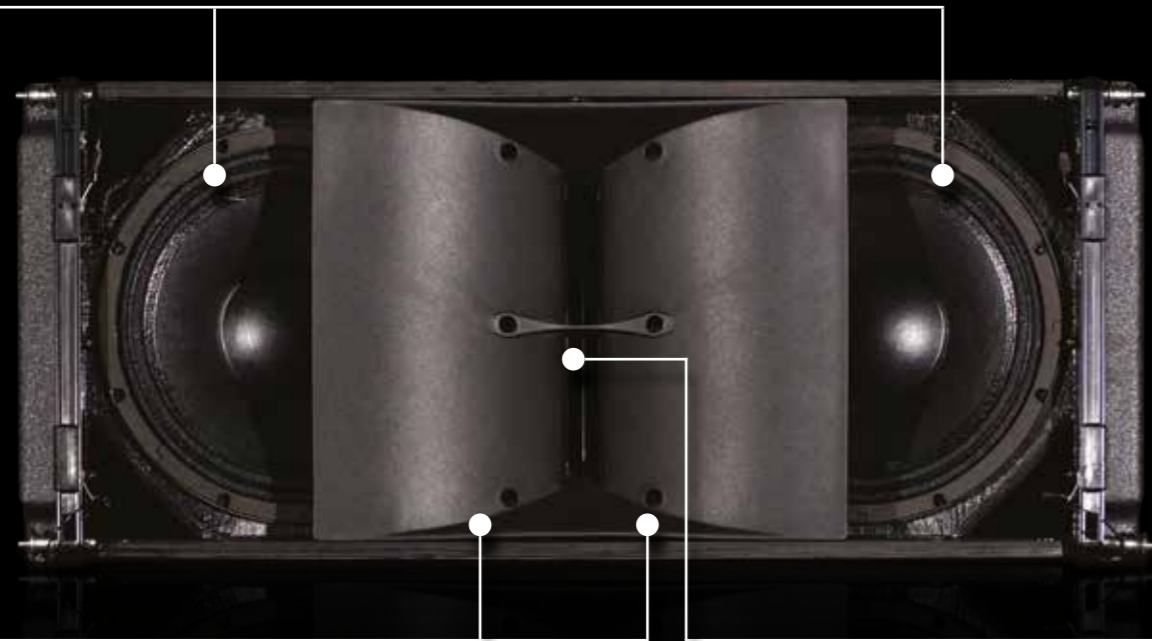

REMARKABLE HEADROOM

The coaxial transducer not only allows an extended low-end reproduction of the MF but guarantees a perfect off-axis coherence along with all the benefits coming from woofers' direct radiation, resulting in an enhanced headroom of the system.

CONTROL AND POWER

The MF+HF is mounted on an exclusively designed waveguide, resulting in a very precise directivity pattern control in the wideband, while the horn conveys a great part of the band to acoustically maximize the output performance.

DIGIPRO G4 AMP TECHNOLOGY

VIO L1610 acoustic engine is driven by a Digipro G4® Class-D amplifier module featuring 1600 W RMS along with the utmost acquisitions in dBTechnologies' amp technology. In fact, the system takes advantage of a one-of-a-kind low latency processing resulting from its powerful DSP featuring linear phase FIR filters. The PSU is equipped with PFC (Power Factor Corrector) technology, a feature allowing a very stable and consistent performance of the system, regardless of the quality of the mains and power fluctuations. PFC also grants a worldwide compatibility of the power supply (from 90V to 265V 50/60Hz) and limits power consumption.



SYSTEM TEST

The amp also allows users to run a test on electronics and transducers before, during and after use; the most useful system test ensuring real-time control over the entire PA's health and tour-grade reliability.

ON-BOARD CONTROLS

The acoustic configuration of the system in use can be also optimized via onboard controls (2 rotary encoders) allowing DSP presets for Speaker Coupling and High Frequencies compensation.

TRANSPORT & INSTALLATION ACCESSORIES

AF-VI01	DT-VIOL210	DT-VIOL210L	DTT-VIOL210	DRK-210	FSA-VIOL210	GSA-VIOL210	TC-VIOL210

CABLES

TF-VI02	TF-VI01	
		<p>DAC-70 XLR-XLR audio cable (70 cm).</p> <p>DCK-27T Cable-Set containing 2x DAC-70 and 2x DPTC-70L.</p> <p>DAC-500 XLR-XLR audio cable (500 cm).</p> <p>DPTC-70L PowerCON TRUE1-PowerCON TRUE1 power link cable (70cm).</p> <p>DPTC-1000M Mains PowerCON TRUE1 cable (10m). Different plugs available for several countries.</p> <p>DPTC-2000M Mains PowerCON TRUE1 cable (20m). 16A CekON.</p> <p>RDC-45F RJ45 to XLR 3 poles female conversion cable, 6 cm length. It converts from RDNet RJ45 to XLR.</p> <p>RDC-45M RJ45 to XLR 3 poles male conversion cable, 6 cm length. It converts from RDNet RJ45 to XLR.</p> <p>RJ45-RJ45-150 RJ45-RJ45 link cable (150cm) for RDNet speakers. EtherCON connectors.</p> <p>RJ45-RJ45-75 RJ45-RJ45 link cable (75cm) for RDNet speakers. EtherCON connectors.</p> <p>CAT6-CAT6-100 CAT6-CAT6 link cable (100cm) for DANTE™ AoIP and RDNet. EtherCON connectors.</p> <p>CAT6-CAT6-170 CAT6-CAT6 link cable (170cm) for DANTE™ AoIP and RDNet. EtherCON connectors.</p> <p>CAT6-CAT6-500 CAT6-CAT6 link cable (500cm) for DANTE™ AoIP and RDNet. EtherCON connectors.</p>

ADVANCED NETWORKABILITY

Digipro G4 amp comes with a modular slot for expansion cards: as a default, VIO L1610 is equipped with dBTechnologies RDNet card for real-time remote control via Aurora Net software. Nevertheless, the system is ready for upgrades with Audinate Dante™ AoIP protocol for digital audio stream as well as real-time control purposes.

As a support for networking purposes, each VIO L1610 cabinet is equipped with a Near Field Communication (NFC™) system and a frontal LED used to recognize every single module within the remote control software Aurora Net.



TOUR GRADE ENCLOSURE

VIO L1610's cabinet is made of robust plywood coated with a black polyurea anti-scratch finish. The amp module is protected by a magnetic rubber rain cover designed to provide weatherproofing even when the cabinet is serving as a downfill mounted on a steep angle.

An impressive power/size ratio keeps the cabinet to a 31.3 kg (69 lbs) overall weight.

Side metal handles and back wooden handles have been designed to furtherly ease transport, set up, and dismantling operations.



COMPATIBILITY WITH VIO FAMILY

Just like any member of VIO family, VIO L1610 has been designed keeping in mind complete compatibility among VIO systems.

Although its remarkable audio performance makes VIO L1610 a powerful yet compact main PA system, both its acoustic and mechanical design makes it the perfect downfill for large VIO L212 systems.

TF-VIO2 adapter allows to easily rig VIO L1610 modules under a VIO L212 array.

VIO'S SMART RIGGING SYSTEM

VIO L1610 comes with VIO series' peculiar 3-point rigging system allowing a smooth and fast set up. The 2 front links easily connect the modules. The back central rigging strand is equipped with a ring-type link allowing users to set the relative splay angles ranging from 1° to 10° thanks to 1 single pin.

Splay angles can be set directly in the dedicated transport cart DT-VIOL210L which houses 4 modules. While lifting the array, the rigging strand will automatically block the preset angles with no heavy lifting required.

The flying frame DRK-210 allows smooth flying operations and system lifting.



VIO L210



2-WAY ACTIVE LINE ARRAY SYSTEM

WOODEN ENCLOSURE COATED WITH POLYUREA

NETWORK READY WITH AN INTEGRATED RDNET PORT

SMOOTH CONFIGURATION AND SET UP OPERATIONS THANKS TO THE INTEGRATED 3-POINT RIGGING HARDWARE

UP TO 6 MODULES IN A SINGLE 16A 230V CIRCUIT

LIGHTWEIGHT NEODYMIUM MAGNETS FOR ALL TRANSDUCERS

ALUMINIUM PHASE PLUGS FOR AN EXTREMELY CONSTANT DISPERSION

ON-BOARD DOUBLE ROTARY EQ CONTROL SYSTEM FOR PRECISE TUNING

ADVANCED DSP FEATURING LINEAR PHASE FIR FILTERS FOR IMPROVED INTELLIGIBILITY

BUILT-IN INCLINOMETER

EXCLUSIVELY DESIGNED HF WAVEGUIDE FOR IMPRESSIVE THROW DISTANCE AND PHASE COHERENCE

WHITE VERSION AVAILABLE

INTRODUCTION TO VIO L210

As a result of many years' experience developing solutions for powered line array systems, VIO L210 reaches the next level among dBTechnologies' speaker range aimed at larger sound reinforcement applications. The internal acoustic design and sound processing developed by dBTechnologies' R&D department merge to deliver outstanding performances in terms of sound pressure, coverage coherence, intelligibility and sound definition.

Speaker Type	2-Way Active Line Array Module
Usable Bandwidth [-10dB]	62 - 20,000 Hz (FW 1.x) / 57 - 21,000 Hz (FW 2.x)
Frequency Response [-6dB]	67 - 18,000 Hz (FW 1.x) / 62 - 20,000 Hz (FW 2.x)
Max SPL	One Unit: 135 dB
HF	1x 1.4", 3" v.c. - Neodymium, Titanium diaphragm
LF	2x 10", 2.5" v.c. - Neodymium
Phase Correction	Aluminum Phase Plug
Horizontal Directivity	100°
Vertical Directivity	depends on array size and configuration
Amplifier	900 W RMS Class-D Digipro® G3
Cooling	Convection
Power Supply	Auto-range SMPS
Controller	DSP 28/56 bit
AD/DA Converter	24 bit/48 kHz
Limiter	Dual Active Multiband Peak, RMS, Thermal
Processing (filters)	FIR Linear phase
Signal Input	1x XLR female, 1x RJ45 Link (RDNet) 1x USB Data Service
Signal Output	1x XLR male, 1x RJ45 Link (RDNet)
Power Socket	1x PowerCON TRUE1 In 1x PowerCON TRUE1 Out
Controls	1x Speaker Coupling (7 presets) 1x HF Compensation (8 presets) 1x Input Attenuation Rotary Switch
Special Features	Opto-isolated floating pre-amp Inclinometer
Housing	Multiplex plywood - Polyurea painting
Housing Design	Trapezoidal 10°
Handles	1x Side, 2 on back
Rain cover	Included
Rigging Points	Integrated rigging hardware
Width x Height x Depth	720 x 320 x 520 mm (28.35 x 12.6 x 20.47 in)
Weight	28.6 kg (63 lbs)

UNIQUE ACOUSTIC DESIGN



FUNCTIONAL YET UNOBTRUSIVE DESIGN

Made of solid multiplex plywood coated with a black polyurea finish, the housing is fronted with a black grille which complete a sober, unobtrusive look which can easily adapt to any scenic design. The speaker's cabinet is easy to tote thanks to its 4 handles, 1 per side and 2 on the back, and its amplifier module is protected with an integrated black raincover.

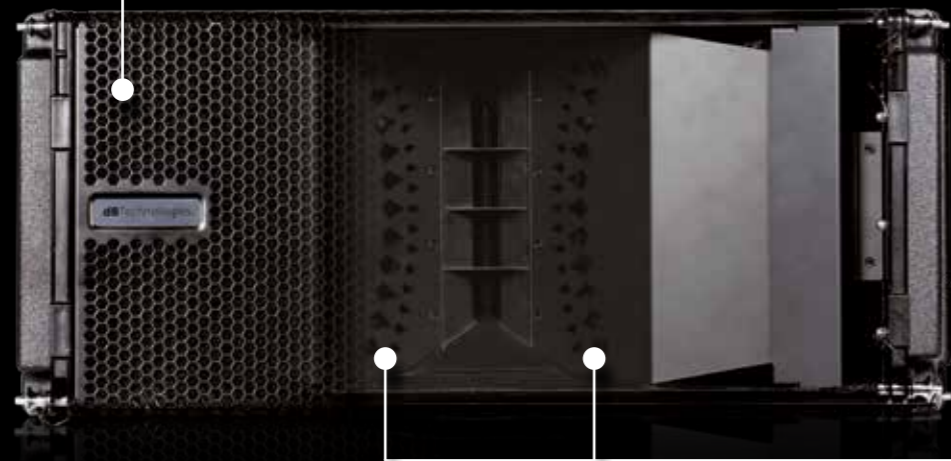

WOOFERS

The two premium 10" neodymium transducers, positioned in a V form and sealed in a bass reflex enclosure, have been custom-designed to improve efficiency. In fact, their voice coils, made of copper plus aluminum coating, are designed to last even in the most demanding conditions, providing an accurate transient response and an extended low-end reproduction. Furthermore, these transducers have been specifically designed for the VIO in order to make the most of the system.



PHASE PLUG

Acoustic enclosure is completed by two massive aluminum phase plugs located in front of both 10" woofers. Their external surface is the prosecution of the constant directivity high-frequency waveguide.

Each phase plug features 26 diamond-shaped holes essential to reduce the interference between the two LF emission points and to improve frequency and transient response.



HIGH-FREQUENCY

One single 3" voice coil compression driver (1.4" exit throat) accurately delivers high frequencies. The waveguide contributes to create a cylindrical wavefront, allowing a very precise high-frequency directivity control, much to the advantage of the system's throw-distance.

The crossover frequency between the 2 ways lows down to 950 Hz and each module guarantees a uniform 100° horizontal coverage.



TRANSPORT & INSTALLATION ACCESSORIES

AF-V101	DT-VIOL210	DT-VIOL210L	DTT-VIOL210	DRK-210	FSA-VIOL210	GSA-VIOL210	TC-VIOL210
Adapter frame for flying VIO L208 under VIO S118/VIO L210/L1610 and groundstacking VIO L208/L210/L1610 on any VIO sub.	Touring cart for 4 VIO L210/L1610 modules and a DRK-210 flybar. Including 4 poles and a wooden lid.	Touring cart for 4 VIO L210/L1610 modules. Light version	Wooden cover top for DT-VIOL210L.	Flybar for VIO L210 and VIO L1610. For flown and groundstacked configurations.	Adapter to fly VIO L210/L1610 under VIO S118.	Adapter to stack VIO L210/L1610 on top of VIO S118.	Transport cover for 4 VIO L210/L1610 on DT-VIOL210 or on DT-VIOL210L. Waterproof.

CABLES

TF-V102	TF-V101	DAC-70	XLR-XLR audio cable (70 cm).
		DCK-27T	Cable-Set containing 2x DAC-70 and 2x DPTC-70L.
Transition frame for flying VIO L210/L1610 under VIO L212.	Transition frame for flying VIO L208 under VIO L210/L1610.	DAC-500	XLR-XLR audio cable (500 cm).
		DPTC-70L	PowerCON TRUE1-PowerCON TRUE1 power link cable (70cm).
		DPTC-1000M	Mains PowerCON TRUE1 cable (10m). Different plugs available for several countries.
		DPTC-2000M	Mains PowerCON TRUE1 cable (20m). 16A CekON.
		RDC-45F	RJ45 to XLR 3 poles female conversion cable. 6 cm length. The cable converts from RDNet RJ45 to XLRF.
		RDC-45M	RJ45 to XLR 3 poles male conversion cable. 6 cm length. The cable converts from RDNet RJ45 to XLRM.
		RJ45-RJ45-150	RJ45-RJ45 link cable (150cm) for RDNet speakers. EtherCON connectors.
		RJ45-RJ45-75	RJ45-RJ45 link cable (75cm) for RDNet speakers. EtherCON connectors.
		CAT6-CAT6-100	CAT6-CAT6 link cable (100cm) for DANTE™ AoIP and RDNet. EtherCON connectors.
		CAT6-CAT6-170	CAT6-CAT6 link cable (170cm) for DANTE™ AoIP and RDNet. EtherCON connectors.
		CAT6-CAT6-500	CAT6-CAT6 link cable (500cm) for DANTE™ AoIP and RDNet. EtherCON connectors.

ADVANCED DSP

ADVANCED DSP PAIRED WITH NOTABLE EFFICIENCY

The module features a 900W RMS Class D Digipro G3 highly efficient amplifier allowing the system to achieve up to 135 dB SPL. High efficiency is a key feature of the VIO L210: it is actually possible to connect up to 6 modules on a single 16A 230V circuit.

The amplifier also features an auto-range circuit and is fed via PowerCON TRUE1 waterproof connectors.

A perfectly coherent coverage is granted even at a long distance thanks to advanced sound processing with FIR filters. The pre-amp module is also equipped with a digital optical isolation on the signal input stage, which makes the system more resistant to any interference.



COMPLETE EQ CONTROLS

VIO L210 features a double rotary user interface to process the system manually. The first rotary is dedicated to low frequency adjustments in order to control coupling effects depending on the array dimensions. The second rotary helps to compensate for the high frequencies loss due to throw distance.

Both rotaries features several accurate presets, while the prediction software dBTechnologies Composer provides for more precise configurations. Any preset can be easily changed remotely via dBTechnologies Network.

FLYING HARDWARE

SMART RIGGING HARDWARE & ACCESSORIES

The VIO L210 comes with a built-in 3-point rigging system allowing a smooth and fast set up of the system. The 2 front links easily connect the modules from any angle.

The back central rigging strand is equipped with a hook type link to set the relative splay angles, determined via the prediction software dBTechnologies Composer.

While lifting up the array, the rigging strand will automatically block the system at the preset angles. Splay angles can be set directly while the system is still located on the transport cart DT-VIOL210, which houses up to 4 modules.



FLYING AND STACKING CABINETS

The dedicated flying frame DRK 210 comes with 2 hooks whose design allows to set a more precise inclination of the array. The DRK 210 can also serve as a groundstacking accessory to secure VIO L210 cabinets on a VIO S318 subwoofer. When not in use, the flying frame can be fixed and stored on the top lid of DT-VIOL210 transport cart. Even details like cables mounts, or the attachment of a laser inclinometer are included in the design.

ROTARY 1 - SPEAKER COUPLING PRESETS

Depending on the dimension of the array, the coupling effect affects frequency response. This dedicated "speaker coupling" control allows the user to attenuate the mid-low frequency according to the total number of line array cabinets.

SPEAKER COUPLING		
NUMBER OF CABINETS	2 → 6	A
	7 → 8	B
	9 → 10	C
	11 → 12	D
	13 → 14	E
	more than 15	F
	Bass boost service	G

ROTARY 2 - HF COMPENSATION PRESETS

Being a considerable long-throw system, VIO L210 is capable to provide incredibly flat response all over the target area also thanks to the high frequencies compensation control. Choosing among the different presets, allows the user to compensate high frequencies loss due to air absorption in each cabinet.

HIGH FREQ. COMPENSATION		
THROW DISTANCE m [ft]	FLAT	1
	front fill 0 → 5 [16]	2
	6 [17] → 20 [66]	3
	21 [67] → 30 [98]	4
	31 [99] → 40 [131]	5
	41 [132] → 50 [164]	6
	51 [165] → 60 [197]	7
	more than 61 [198]	8



VIO L1608



3-WAY TRI-AMPED ACTIVE LINE ARRAY SYSTEM

1600W RMS AMP

FULL RANGE SMPS WITH PFC

LOW LATENCY DSP FEATURING LINEAR PHASE FIR FILTERS

SEAMLESS INTEGRATION ACROSS THE VIO ECOSYSTEM

MODULAR SLOT FOR NETWORK AND DIGITAL AUDIO EXPANSION CARDS - A2NET CARD INSTALLED

SIDE-FIRING BASSFLEX PORTS

NFC™ + FRONT LED IDENTIFICATION SYSTEM

SYSTEM TEST FOR QUICK TRANSDUCERS DIAGNOSTICS

ENHANCED 3-POINT RIGGING SYSTEM

3-WAY IN THE MOST COMPACT SIZE

VIO L1608 is a 3-way, tri-amplified active line array module that delivers dramatic output, refined clarity and consistent coverage from a deceptively compact footprint. It advances dBTechnologies' research into precision-scaled acoustic architecture - in simpler words, bringing three-way performance to an enclosure the size of a traditional 2-way dual-8" array.

Speaker Type	3-Way Tri-Amplified Active Line Array Module
Usable Bandwidth [-10dB]	67 - 20,000 Hz
Frequency Response [-6dB]	75 - 18,000 Hz
Max SPL	138.5 dB*
MF-HF	1x 1.4" exit, 3"-2" v.c. Coaxial, Neodymium
LF	2x 8", 2.5" v.c. - Neodymium
Horizontal Directivity	110°
Vertical Directivity	depends on array size and configuration
Amplifier	1600 W RMS Class-D
Cooling	Convection
Power Supply	Full-range SMPS with PFC (100V--240V-, 50-60Hz)
Controller	DSP 32 bit
AD/DA Converter	24 bit/96 kHz
Limiter	Dual Active Multiband Peak, RMS, Thermal
Processing (filters)	FIR Linear phase
Signal Input	1x XLR female, 1x RJ45 Link (A2NET) 1x USB Data Service
Signal Output	1x XLR male, 1x RJ45 Link (A2NET)
Power Socket	1x PowerCON TRUE1 In 1x PowerCON TRUE1 Out
Controls	1x switch Flat - service/user 1x switch System test 1x led ON 1x led STATUS 1x led SIGNAL 1x led LIMITER 1x LED TEST 1x frontal ID LED
Special Features	NFC™ and Frontal LED Identification System 380V Resistant SMPS IPOS Intelligent Power-On Sequence Opto-isolated floating pre-amp System Test (transducers diagnostics) Inclinometer
Housing	Wooden - Polyurea painting
Handles	1x Side, 2 on back
Rain cover	Included
Rigging Points	Integrated 3-point flying hardware
Width x Height x Depth	600 x 260 x 390 mm (25.98 x 10.23 x 15.35 in)
Weight	22 kg (48.5 lbs)

ULTRA-EFFECTIVE ACOUSTIC DESIGN

At the heart of the system are premium neodymium transducers, including a high-performance B&C coaxial MF-HF driver and dual 8" LF woofers, all powered by a Class-D 1600W RMS amplifier. This configuration ensures precise low-frequency reproduction, detailed midrange and smooth high-frequency response with outstanding clarity, dynamics and elevated SPL.

The coaxial component, fully controlled by the waveguide, ensures exceptionally smooth horizontal dispersion by extending part of the low-mid range into the horn, resulting in natural off-axis response and coherent, full-range performance.

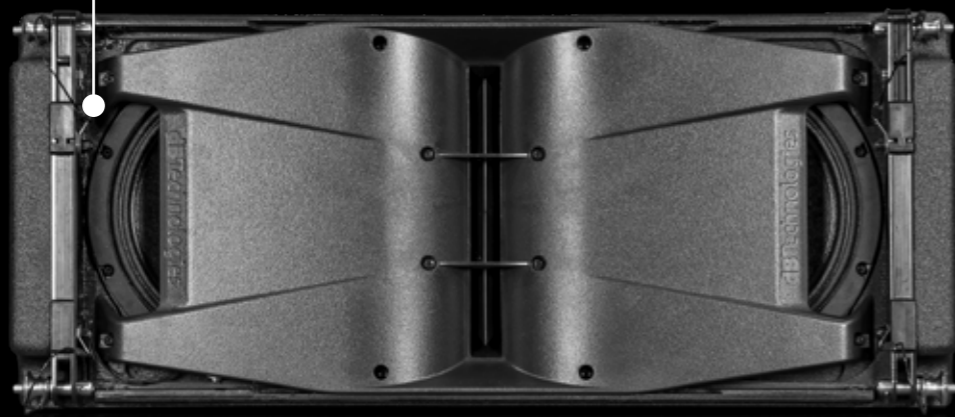

Designed for real-world production demands, VIO L1608 incorporates several engineering principles that shaped the success of the VIO L1610, adapted here for the dual-8" platform. This includes VIO 3-point rigging system for faster deployment and current-generation VIO technologies such as inclinometer integration, opto-isolated preamps, NFC-assisted positioning, and a bright front ID LED for positioning and identification.

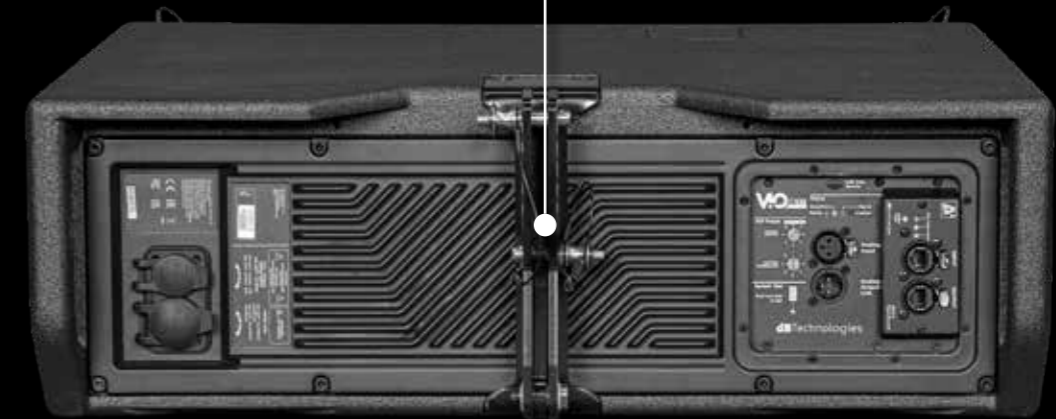

VIO L1608 comes equipped with an A2Net card on-board, enabling high-resolution digital audio distribution and full system control. The module also supports network remote control, ensuring seamless integration into modern infrastructures and offering engineers precise, reliable management capabilities. The modular card slot supports optional Dante™ networking cards, providing maximum flexibility for different infrastructures and audio workflows.

RAINCOVER INCLUDED

The amp module is always protected from rain thanks to the integrated raincover.

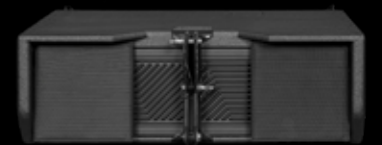

TRANSPORT & INSTALLATION ACCESSORIES

AF-VIO1	DT-28	DTT-VIOL208	DRK-28	DSA-VIOL208	EFK-2	STA-DRK	TF-VIO1
Adapter frame for flying VIO L208/L1608 under VIO S118/VIO L210 and groundstacking VIO L208/L210 on any VIO sub.	Touring cart for 4 VIO L208/L1608 modules and a DRK-28 flybar.	Wooden cover top for DTT-VIOL208.	Flybar for VIO L1608 and VIO L208.	Groundstack adapter for VIO L208/L1608 on VIO S118 and S118R with or without pole.	Groundstack extension feet kit for AF-VIO1 (maximum 6 tops).	Spigot adapter for DRK-208.	Transition frame for flying VIO L208/L1608 under VIO L210.

COVERS

TC-VIOL208
Transport cover for 4 VIO L208/L1608 on DT-28. Waterproof

CABLES

DAC-70	XLR-XLR audio cable (70 cm).
DCK-27T	Cable-Set containing 2x DAC-70 and 2x DPTC-70L.
DAC-500	XLR-XLR audio cable (500 cm).
DPTC-70L	PowerCON TRUE1-PowerCON TRUE1 power link cable (70cm).
DPTC-1000M	Mains PowerCON TRUE1 cable (10m). Different plugs available for several countries.
DPTC-2000M	Mains PowerCON TRUE1 cable (20m). 16A CekoN.
RDC-45F	RJ45 to XLR 3 poles female conversion cable, 6 cm length. The cable converts from RDNet RJ45 to XLR.
RDC-45M	RJ45 to XLR 3 poles male conversion cable, 6 cm length. The cable converts from RDNet RJ45 to XLR.
RJ45-RJ45-150	RJ45-RJ45 link cable (150cm) for RDNet speakers. EtherCON connectors.
RJ45-RJ45-75	RJ45-RJ45 link cable (75cm) for RDNet speakers. EtherCON connectors.
CAT6-CAT6-100	CAT6-CAT6 link cable (100cm) for DANTE™ AoIP and RDNet. EtherCON connectors.
CAT6-CAT6-170	CAT6-CAT6 link cable (170cm) for DANTE™ AoIP and RDNet. EtherCON connectors.
CAT6-CAT6-500	CAT6-CAT6 link cable (500cm) for DANTE™ AoIP and RDNet. EtherCON connectors.

SIDE-FIRING BASSREFLEX PORT

Side-Firing Bassreflex Port geometry enhances internal airflow and acoustic loading, supporting output performance that far exceeds expectations for the cabinet's reduced physical volume.



HARDWARE & ACCESSORIES

As part of the VIO ecosystem, VIO L1608 benefits from matched phase response, latency and sensitivity across systems running firmware 2.0 or later, allowing seamless integration with VIO L1610, L212 and other modules in the platform. The new DRK-28 flybar supports both flown and stacked configurations and transports on the dolly, simplifying logistics and reinforcing a unified deployment workflow.



VIO L208



2-WAY ACTIVE LINE ARRAY SYSTEM

NEW ACOUSTIC DESIGN FEATURING ALL-IN-ONE PHASE PLUG AND HF HORN FRONT PANEL

LOW-LATENCY PROCESSING THANKS TO POWERFUL DSP WITH LINEAR-PHASE FIR FILTERS

BUILT-IN INCLINOMETER

DESIGNED FOR OPTIMIZED ACOUSTIC AND

MECHANICAL COMPATIBILITY WITH VIO L210

FULL COMPLIANCE WITH AURORA NET REMOTE CONTROL SOFTWARE

DSP PRESETS FOR MAXIMUM ACOUSTIC CUSTOMIZATION

BUILT-IN FLYING HARDWARE ALLOWING FAST & EASY SET UP AND FLYING OPERATIONS

WHITE VERSION AVAILABLE

VIO GOES COMPACT WITH L208

Offering lighter and faster rigging elements, featuring an unique acoustic design, combining long throw and detailed audio performance, the new VIO L208 is both a powerful yet compact stand-alone line array system, and a fully compatible down-fill for VIO L210 + VIO L208 hybrid systems, completed by VIO S Active subwoofers.

Speaker Type	2-Way Active Line Array Module
Usable Bandwidth [-10dB]	69 - 20,000 Hz (FW 1.x) / 69 - 21,000 Hz (FW 2.x)
Frequency Response [-6dB]	75 - 18,000 Hz (FW 1.x) / 75 - 20,000 Hz (FW 2.x)
Max SPL	One Unit: 133.5 dB
HF	1x 1.4", 3" v.c. - Neodymium
LF	2x 8", 2" v.c. - Neodymium
Phase Correction	All-in-one panel with phase corrector
Horizontal Directivity	100°
Vertical Directivity	depends on array size and configuration
Amplifier	900 W RMS Class-D Digipro® G3
Cooling	Convection
Power Supply	Auto-range SMPS
Controller	DSP 28/56 bit
AD/DA Converter	24 bit/48 kHz
Limiter	Dual Active Multiband Peak, RMS, Thermal
Processing (filters)	FIR Linear phase
Signal Input	1x XLR female, 1x RJ45 Link (RDNet) 1x USB Data Service
Signal Output	1x XLR male, 1x RJ45 Link (RDNet)
Power Socket	1x PowerCON TRUE1 In 1x PowerCON TRUE1 Out
Controls	1x Speaker Coupling (7 presets) 1x HF Compensation (8 presets) 1x Input Attenuation Rotary Switch
Special Features	Opto-isolated floating pre-amp Inclinometer
Housing	Multiplex plywood - Polyurea painting
Handles	1x Side, 2 on back
Rain cover	Included
Rigging Points	Integrated 3-point flying hardware
Width x Height x Depth	600 x 260 x 390 mm (25.98 x 10.23 x 15.35 in)
Weight	18.1 kg (39.9 lbs)

ULTRA-EFFECTIVE ACOUSTIC DESIGN



COMPACT & LIGHTWEIGHT

VIO L208 is a 2-way active line array system equipped with 2x 8" neodymium woofers and 1x 1.4" neodymium compression driver (3" voice coil). Everything enclosed in a sturdy wooden cabinet.

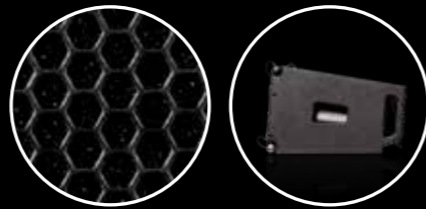

THE FRONT PANEL

The transducers are positioned behind an all-in-one panel which acts as a phase-plug and a HF horn. The waveguide behind this panel contributes to the creation of a cylindrical wavefront, much to the advantage of hi-freq throw distance.



FIR FILTERS

A perfectly coherent emission is granted thanks to advanced sound processing with FIR filters. The pre-amp module is also equipped with a digital optical isolation, guaranteeing interference-free input signal. VIO L210 features on board presets allowing users to process the system manually. Any preset can be easily changed remotely via Aurora Net control software.

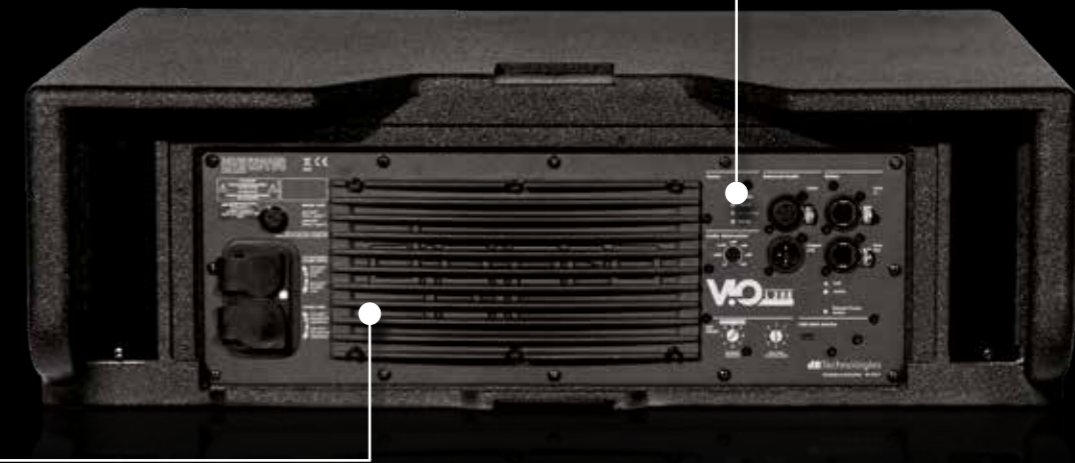

AMPLIFIER

Each module of VIO L208 is driven by a Class-D Digipro G3 900W amp module with auto-range PSU.

RAINCOVER INCLUDED

The amp module is always protected from rain thanks to the integrated raincover.



TRANSPORT & INSTALLATION ACCESSORIES

AF-VIO1	DT-28	DTT-VIO1208	DRK-28	DSA-VIO1208	EFK-2	STA-DRK	TF-VIO1
Adapter frame for flying VIO L208/L1608 under VIO S118/VIO L210 and groundstacking VIO L208/L210 on any VIO sub.	Touring cart for 4 VIO L208/L1608 modules and a DRK-28 flybar.	Wooden cover top for DT-28.	Flybar for VIO L208 or VIO L1608.	Groundstack adapter for VIO L208/L1608 on VIO S118 and S118R with or without pole.	Groundstack extension feet kit for AF-VIO1 (maximum 6 tops).	Spigot adapter for DRK-208.	Transition frame for flying VIO L208/L1608 under VIO L210.

COVERS

TC-VIO1208
Transport cover for 4 VIO L208/L1608 on DT-28. Waterproof

CABLES

DAC-70	XLR-XLR audio cable (70 cm).
DCK-27T	Cable-Set containing 2x DAC-70 and 2x DPTC-70L.
DAC-500	XLR-XLR audio cable (500 cm).
DPTC-70L	PowerCON TRUE1-PowerCON TRUE1 power link cable (70cm).
DPTC-1000M	Mains PowerCON TRUE1 cable (10m). Different plugs available for several countries.
DPTC-2000M	Mains PowerCON TRUE1 cable (20m). 16A CekoN.
RDC-45F	RJ45 to XLR 3 poles female conversion cable, 6 cm length. The cable converts from RDNet RJ45 to XLR.
RDC-45M	RJ45 to XLR 3 poles male conversion cable, 6 cm length. The cable converts from RDNet RJ45 to XLR.
RJ45-RJ45-150	RJ45-RJ45 link cable (150cm) for RDNet speakers. EtherCON connectors.
RJ45-RJ45-75	RJ45-RJ45 link cable (75cm) for RDNet speakers. EtherCON connectors.
CAT6-CAT6-100	CAT6-CAT6 link cable (100cm) for DANTE™ AoIP and RDNet. EtherCON connectors.
CAT6-CAT6-170	CAT6-CAT6 link cable (170cm) for DANTE™ AoIP and RDNet. EtherCON connectors.
CAT6-CAT6-500	CAT6-CAT6 link cable (500cm) for DANTE™ AoIP and RDNet. EtherCON connectors.

EASY RIGGING

The dedicated 3-point flying frame DRK-208 allows to set a precise inclination of the array and is ready to carry an optional inclinometer laser pointer. When not in use, the flybar can be easily stored in the transport cart.

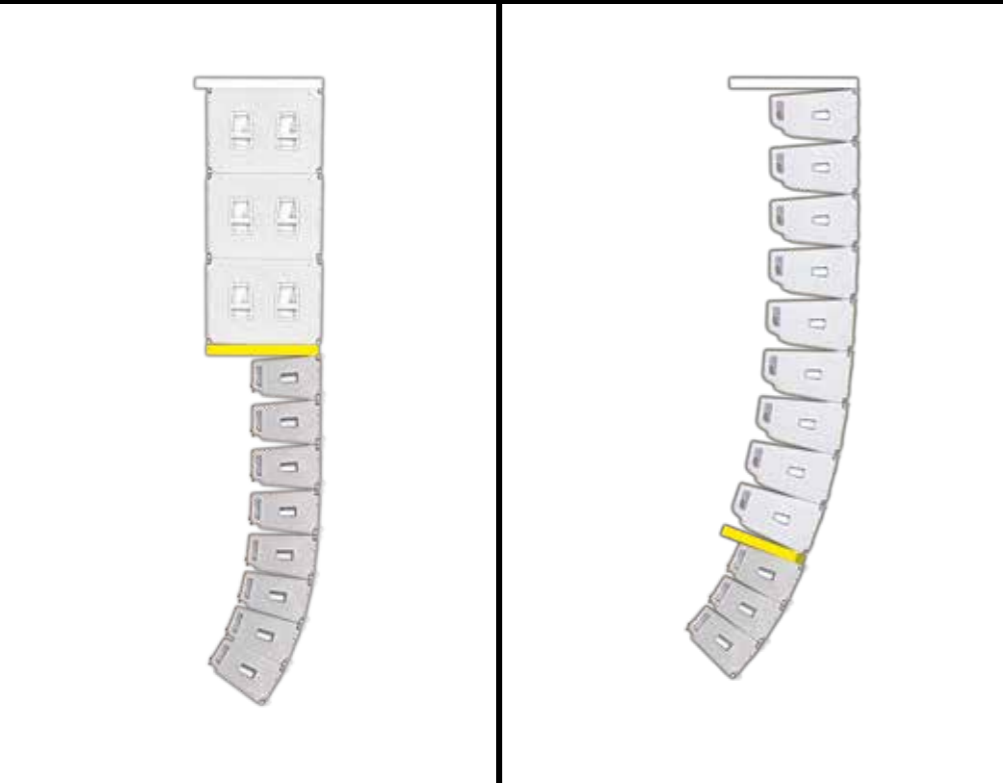

HARDWARE & ACCESSORIES

AF-VIO1 accessory enables rigging under a VIO S118 flyable subwoofer or, alternatively, as downfill in larger VIO L210 or L1610 systems. The same accessory also serves as safety interface in stacked configuration on VIO subs.

A lighter accessory transition frame TF-VIO1 allows the installation of VIO L208 under flown VIO L210 only.

Just like larger VIO L210 system, VIO 208's wooden enclosure comes with a built-in rigging system made for simplicity and speed: a back central rigging strand allows to set the relative splay angles, directly in the dedicated transport cart DT-VIOL208, able to house 4 modules plus 1 flying bar. While lifting up the array, the rigging strand will automatically block the systems at the preset angles with no need for heavy lifting.

ACTIVE SUBWOOFERS

The complete assortment of VIO line arrays, VIO C and VIO X full-range family, requests multiple solutions to deliver lower frequencies following the requirements of specific set-ups, keeping in mind ease of deployment and versatility. This is why the VIO S series was born: a family of active subwoofers in different sizes and designs, designed to cover a broad range of acoustic requirements.



VIO S218

VIO S218F

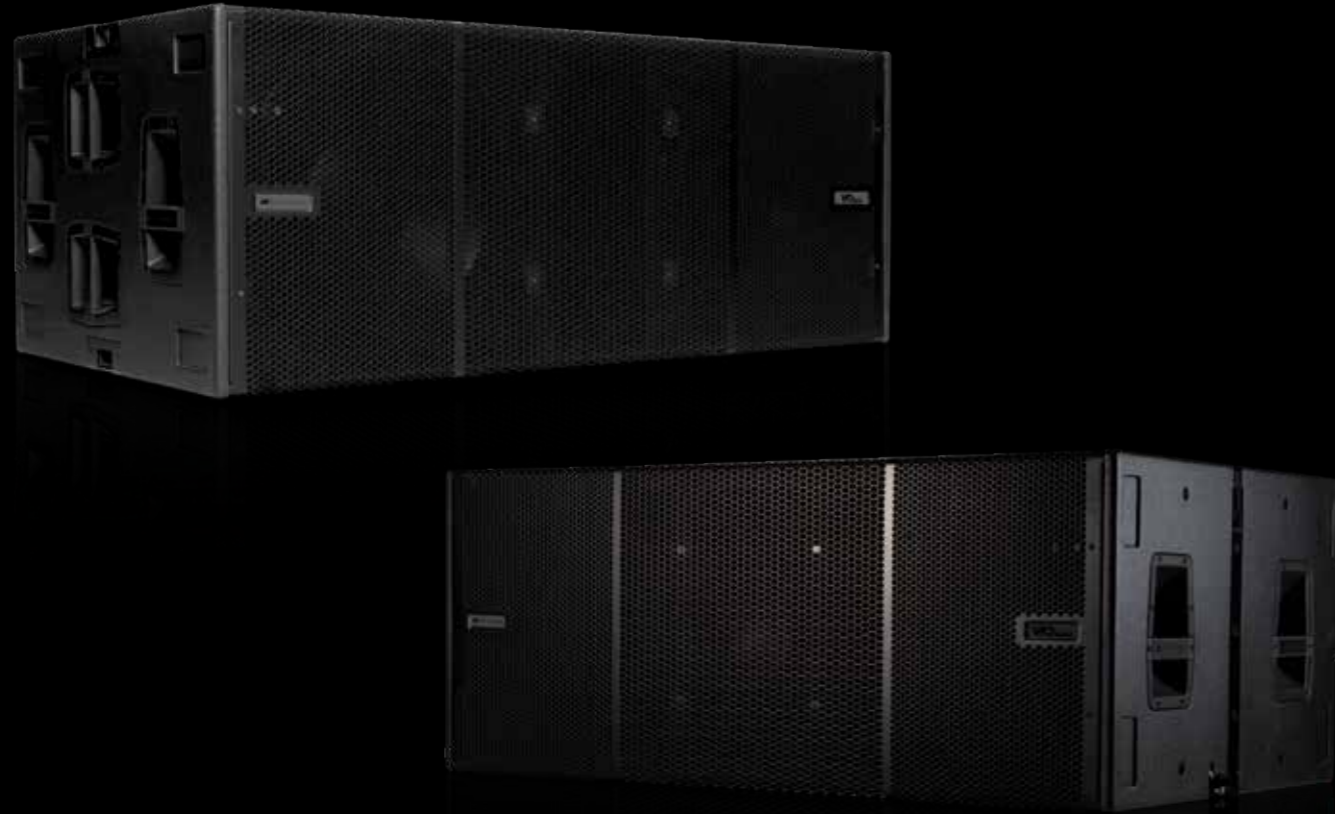

2x 18" NEODYMIUM WOOFERS

ON BOARD DELAY UP TO 9.9MS

3200W RMS DIGIPRO G4 AMP TECHNOLOGY

CARDIOID STACK PRESET BUTTON

FULL RANGE SMPS WITH PFC

NFC™ + FRONT LED IDENTIFICATION SYSTEM

SMPS 380V RESISTANT

SYSTEM TEST FOR QUICK TRANSDUCERS DIAGNOSTICS

FREQUENCY RANGE EXTENDING DOWN TO 28 HZ (-6DB)

IPOS INTELLIGENT POWER-ON SEQUENCE

OPTO-ISOLATED FLOATING PREAMP BOARD

VIO S218F FLYABLE WITH ACCESSORIES

MODULAR SLOT FOR NETWORK AND DIGITAL AUDIO EXPANSION CARDS

RDNET CARD INSTALLED

BASS-REFLEX POWER

The perfect partner for VIO L212 and VIO L1610 in larger sound reinforcement applications. A simple, effective dual sub configuration designed to enhance the reproduction of the lowest frequencies, boosted by an advanced DSP control and complete network capability.

	VIO S218	VIO S218F
Speaker Type	Active Bassreflex Subwoofer	Active Bassreflex Flyable Subwoofer
Usable Bandwidth [-10dB]	27 Hz - Xover Dipendent	27 Hz - Xover Dipendent
Frequency Response [-6dB]	28 Hz - Xover Dipendent	28 Hz - Xover Dipendent
Max SPL	143 dB	143 dB
LF	2x 18" Neodymium	2x 18" Neodymium
Voice Coil LF	4"	4"
Directivity	Omnidirectional	Omnidirectional
Amplifier	3200 W RMS [2x 1600 W RMS Class-D Digipro® G4]	3200 W RMS [2x 1600 W RMS Class-D Digipro® G4]
Cooling	Passive convection, internal fan	Passive convection, internal fan
Power Supply	Full-range SMPS with PFC (100V~240V-, 50-60Hz)	Full-range SMPS with PFC (100V~240V-, 50-60Hz)
Controller	DSP 32 bit	DSP 32 bit
AD/DA Converter	24 bit/96 kHz	24 bit/96 kHz
Limiter	Peak, RMS, Thermal	Peak, RMS, Thermal
Delay Option	0 - 9.9 ms internal steps of 0.1 ms [on-board]	0 - 9.9 ms internal steps of 0.1 ms [on-board]
Xover Frequency LF-Xover out	Selectable 60-110 Hz + Full Range (8 steps)	Selectable 60-110 Hz + Full Range (8 steps)
LF-Xover out slope	24 dB/Octave	24 dB/Octave
Signal Input	1x XLR balanced 1x USB Data Service	1x XLR balanced 1x USB Data Service
Signal Output	1x XLR balanced	1x XLR balanced
Power Socket	1x PowerCON TRUE1 In 1x PowerCON TRUE1 Out	1x PowerCON TRUE1 In 1x PowerCON TRUE1 Out
Expansion Card	RNet Card (1x RJ45 IN 1x RJ45 Link) Dante Card [Optional]	RNet Card (1x RJ45 IN 1x RJ45 Link) Dante Card [Optional]
Controls	1x Input Attenuation Rotary Encoder 2x Delay Rotary Encoder (0-9.9 ms) 1x Polarity Inversion Switch (0° or 180°) 1x Cardioid mode Switch 1x X-Over Frequency Rotary Encoder (8 steps)	1x Input Attenuation Rotary Encoder 2x Delay Rotary Encoder (0-9.9 ms) 1x Polarity Inversion Switch (0° or 180°) 1x Cardioid mode Switch 1x X-Over Frequency Rotary Encoder (8 steps)
Special Features	NFC™ and Frontal LED Identification System 380V Resistant SMPS IPOS Intelligent Power-On Sequence Opto-isolated floating pre-amp System Test (transducers diagnostics)	NFC™ and Frontal LED Identification System 380V Resistant SMPS IPOS Intelligent Power-On Sequence Opto-isolated floating pre-amp System Test (transducers diagnostics)
Housing	Multiplex plywood - Polyurea painting	Multiplex plywood - Polyurea painting
Additional Features	4x Eyelets for ratchet straps	Built-in brackets for flybar mounting or stacking subs
Handles	4x Side. Aluminium	2x Side. Aluminium
Rain cover	Included	Included
Rigging Points	2x Pick Points on top for DRK-210 rigging frame	2x Pick Points on top for DRK-212/210
Width x Height x Depth	1300 x 520 x 800 mm (51.18 x 20.47 x 31.5 in)	1300 x 520 x 800 mm (51.18 x 20.47 x 31.5 in)
Weight	85.6 kg (188.72 lbs)	100 kg (220 lbs.)

ULTRA-LOW FREQUENCY PUNCH



Featuring a dual 18" subwoofer pairing in a voluminous bass-reflex housing, VIO S218 encompasses a vigorous audio performance and a ultra low frequency punch, extending down to 28 Hz: the perfect bottom end addition to large VIO L212 sound reinforcement systems.

The system's acoustical potential is driven by 2 Digipro G4® Class-D amplifiers delivering a total amount of 3200 W RMS and making this sub the perfect low-end extension of VIO arrays in larger sound reinforcement applications.

The switched mode power supply is equipped with PFC (Power Factor Corrector) which greatly improves the efficiency of the system. This also grants a worldwide compatibility of the power supply (from 100V to 240V 50/60Hz) and limits power consumption. Furthermore, the power supply is 380V resistant, so the final amplifiers will be switched off in case of an undesired strike of 380V current, saving them from any damage.



The high quality multiplex housing is reinforced with a robust polyurea finishing, equipped with 4 aluminum handles per side. The amp module is always protected from the rain thanks to the integrated raincover.



Exclusive technology of VIO S318 amplifier is IPOS (Intelligent Power-On Sequence), a circuit that controls the sequence in which the main power supplies of all units within an array ramp up.

The preamplifier is equipped with a modular slot for expansion cards: as a default, VIO S218 is equipped with dBTechnologies RNet card, for real time remote control via Aurora

Net software. The system is ready for future upgrades with Audinate Dante™ AoIP protocol.

VIO S218 comes with built-in technologies: Near Field Communication (NFC™) proximity sensors are used to determine the position of each box within an array. A LED bulb on the front of the enclosure contributes to help the user to recognize, identify and match

each box on the remote control software Aurora Net.

Users can run system-test on transducers and a real time impedance control. The on-board delay module allows VIO S218 to reach a max 9.9ms delay with 0.1 ms steps. A cardioid stack preset button automatically process the sound of the backward sub in gradient inverted stack configurations, in order to reach maximum cancellation on the rear side.

The preamplifier's floating audio input design grants a digital optical isolation between earth ground from the mains and the audio ground flowing into the preamplifier board. This galvanic isolation greatly improves resistance to interferences and any unwanted buzzing and noises.

Thanks to the integrated USB port, the user will perform firmware upgrades.



TRANSPORT & INSTALLATION ACCESSORIES

AF-V101



Adapter frame for flying VIO L208 under VIO S118/VIO L210 and groundstacking VIO L208/L210 on any VIO sub.

DO-V10S218



Dolly for up to 3x VIO VIO S218 stacked horizontally (wheels included).

DO-V10S218F



Dolly for up to 3x VIO S218F Stacked horizontally (wheels included).

DRK-218F



Flybar for VIO S218F. Max 14 (double hang point) or 10 (single hang point) VIO S218F subwoofers can be hung to DRK-218F.

SWK-18 KIT



Kit consisting of 4 wheels for VIO S318 / VIO S218 back panel.

FC-V10S2



Functional Cover for 2 subs VIO S318 / VIO S218.

TC-V10S2

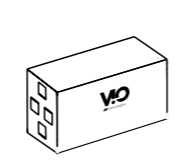

Transport cover for 1 VIO S318 / VIO S218.

COVERS

CABLES

DAC-100	XLR-XLR audio cable (100 cm).
DAC-500	XLR-XLR audio cable (500 cm).
DPTC-160L	PowerCON TRUE1-PowerCON TRUE1 power link cable (160cm).
DPTC-500L	PowerCON TRUE1-PowerCON TRUE1 power link cable (500cm).
DPTC-1000M	Mains PowerCON TRUE1 cable (10m). Different plugs available for several countries.
DPTC-2000M	Mains PowerCON TRUE1 cable (20m). 16A CekON
RDC-45F	RJ45 to XLR 3 poles female conversion cable, 6 cm length. The cable converts from RNet RJ45 to XLR.

RDC-45M	RJ45 to XLR 3 poles male conversion cable, 6 cm length. The cable converts from RNet RJ45 to XLR.
RJ45-RJ45-150	RJ45-RJ45 link cable (150cm) for RNet speakers. EtherCON connectors.
RJ45-RJ45-75	RJ45-RJ45 link cable (75cm) for RNet speakers. EtherCON connectors.
CAT6-CAT6-100	CAT6-CAT6 link cable (100cm) for DANTE™ AoIP and RNet. EtherCON connectors.
CAT6-CAT6-170	CAT6-CAT6 link cable (170cm) for DANTE™ AoIP and RNet. EtherCON connectors.
CAT6-CAT6-500	CAT6-CAT6 link cable (500cm) for DANTE™ AoIP and RNet. EtherCON connectors.

SKY IS THE LIMIT

Packed with our most up-to-date exclusive technologies, VIO S218F widens the possibilities for low frequency reproduction in any larger VIO sound reinforcement deployment.

Now you can extend the range of action of the distinctive VIO S218 subwoofer by flying an array of VIO S218F in the air.

Up to 14 cabinets can be flown with a single DRK-218F flybar.

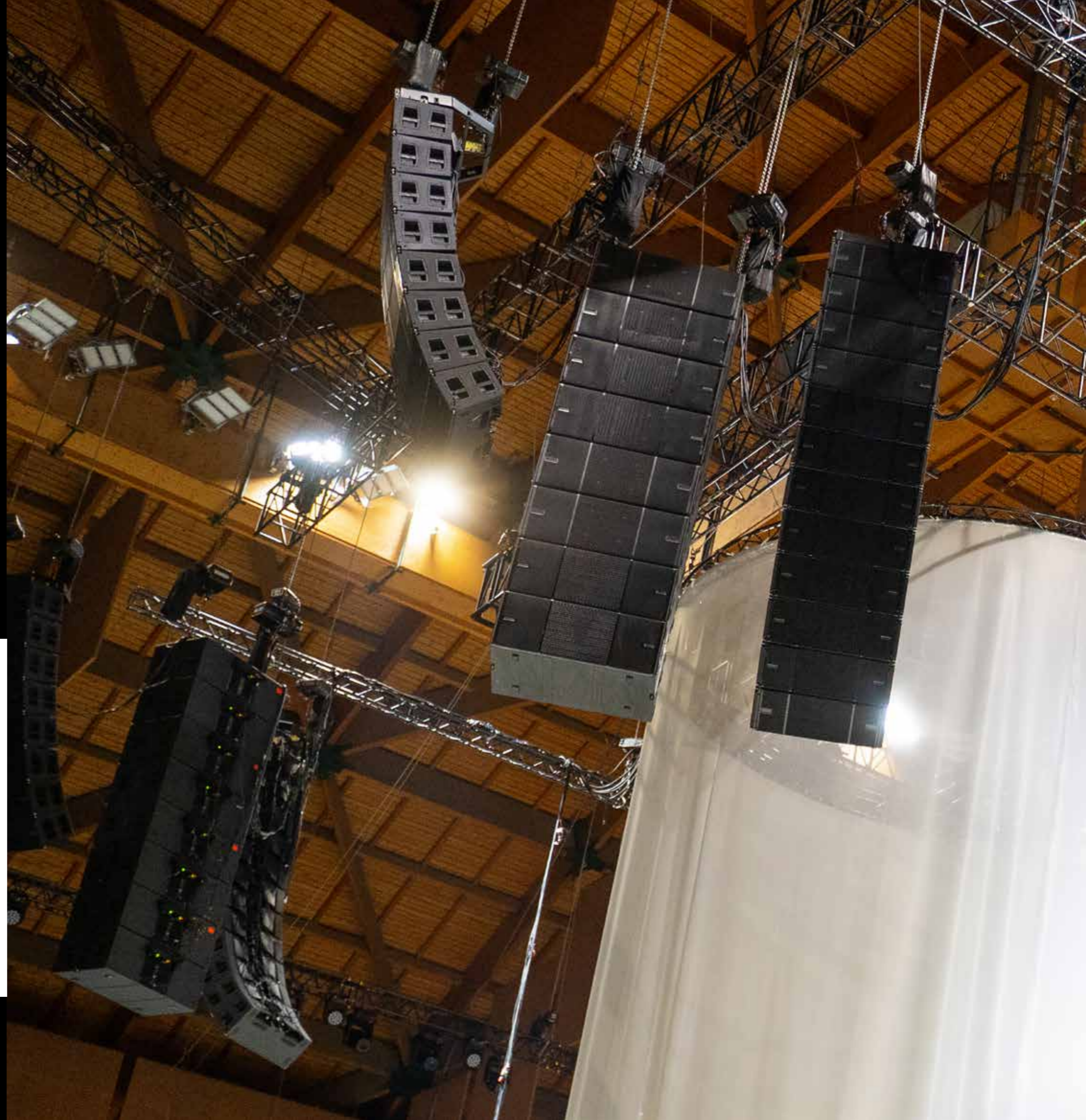

VIO S318

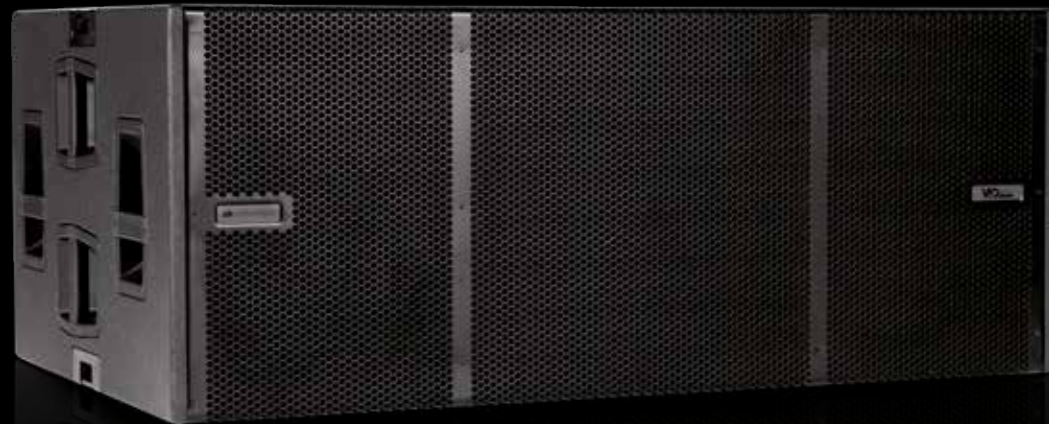

ACTIVE TRI-AMPED 3x 18" BASSREFLEX SEMI-HORN LOADED SUBWOOFER

INTERNAL DESIGN TO MAXIMIZE IN-PHASE FRONTAL EMISSION

ON-BOARD DELAY FOR PERFECT TIME ALIGNMENT

ON-BOARD CARDIOID ARRAY CONFIGURATION PRESET

FREQUENCY RANGE EXTENDING DOWN TO 35HZ

NETWORK READY WITH AN INTEGRATED RDNET PORT

POLYUREA PAINTING ON A ROAD-RESISTANT WOODEN ENCLOSURE

TRI-AMPED ACTIVE SUBWOOFER

VIO S318 subwoofer, a one of a kind system both for its acoustic configuration and majestic output. Indeed, dBTechnologies succeeded in designing an extraordinary powerful triple 18" woofer system while maximizing in-phase frontal emission and extending lower frequencies down to 35 Hz.

Speaker Type	Active Bassreflex, semi-horn loaded subwoofer
Usable Bandwidth [-10dB]	35 Hz [FW 1.x] / 33 Hz [FW 2.x] - Xover Dipendent
Frequency Response [-6dB]	39 Hz [FW 1.x] / 36 Hz [FW 2.x] - Xover Dipendent
Max SPL	143 dB
LF	3x18"
Voice Coil LF	4"
Directivity	Omnidirectional
Amplifier	2700 W RMS Class-D Digipro® G3
Cooling	Convection
Power Supply	Auto-range SMPS
Controller	DSP 32 bit
AD/DA Converter	24 bit/96 kHz
Limiter	Peak, RMS, Thermal
Delay Option	0-9.9 ms internal steps of 0.1 ms
Xover Frequency LF-Xover out	Selectable 70-105 Hz + Full Range (8 steps)
LF-Xover out slope	24 dB/Octave
Signal Input	1 x XLR balanced, 1 x RJ45 Link (RDNet) 1x USB Data Service
Signal Output	1x XLR balanced, 1 x RJ45 Link (RDNet)
Power Socket	1x PowerCON TRUE1 In 1x PowerCON TRUE1 Out
Controls	1x Input Attenuation Rotary Encoder 2x Rotary Encoder (Delay 9.9 ms) 1x Polarity Inversion Switch (0° or 180°) 1x Cardioid mode Switch 1x X-Over Frequency Switch (70-105 Hz + Full-Range steps of 5 Hz)
Special Features	Opto-isolated floating pre-amp
Housing	Multiplex plywood - Polyurea painting
Additional Features	4x Eyelets for ratchet straps
Handles	4x Side, Aluminium
Rain cover	Included
Rigging Points	2x Pick Points on top for DRK-210 rigging frame
Width x Height x Depth	1300 x 520 x 800 mm (51.18 x 20.47 x 31.5 in)
Weight	103.9 kg (229.06 lbs)

OUTSTANDING PERFORMANCE



VIO S318 is equipped with 3x18" woofers, 2 of which are half horn loaded, while the third one is a direct radiation woofer. This way, the sub combines the contribution of two different configurations.

The 3 woofers are aligned in order to achieve a perfect phase response. Its innovative acoustic design contributes in creating an unprecedented performance/dimension ratio for a triple woofer

powered system.

The high quality multiplex housing is reinforced with a robust polyurea finish and equipped with 4 aluminium handles per side. The eyelets on the top of the cabinet allow to fix the DRK-210 flybar, while 4 additional eyelets allow to fasten the load during transport using ratchet straps.



The internal configuration of the 3 woofers maximizes the acoustic radiant surface, delivering a solid sound performance.

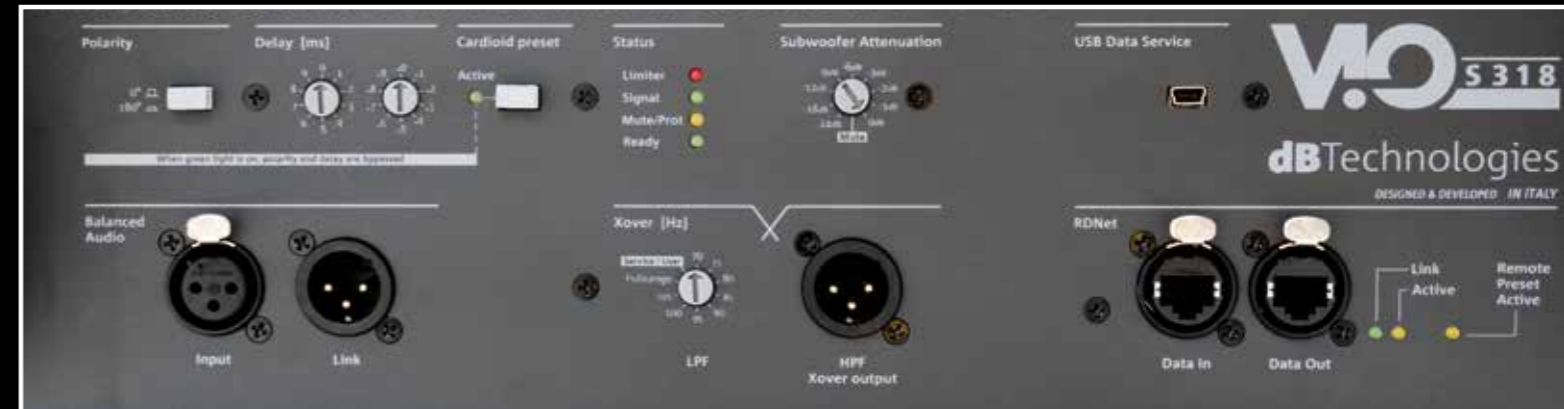

The 3 DIGIPRO G3 amplifiers deliver a total 2700 W RMS power, allowing the system to reach up to 143dB SPL. A solution combining resolute power, compact design and ease of use.

The system features an integrated delay module achieving up to 9.9 ms delay with 0.1 ms steps (a further delay can be set via RDNNet remote control software). The crossover module sets both the low pass filter and the highpass filter for the integrated

crossover output. The system also features an attenuation control, a polarity switch and an RDNNet port for remote control.

In cardioid configurations with 3 subs, the 'cardioid' button allows to process automatically the sub facing backwards, in order to achieve the maximum cancellation. Grooves on the top of the sub facilitates the passage of the cables between the cabinets.

VIO series' simulation models for Ease Focus 3 are available at dbtechnologies.com, as well as the proprietary prediction software dBTechnologies Composer.

TRANSPORT & INSTALLATION ACCESSORIES

AF-V101



Adapter frame for flying VIO L208 under VIO S118/VIO L210 and groundstacking VIO L208/L210 on any VIO sub.

DD-V10S318

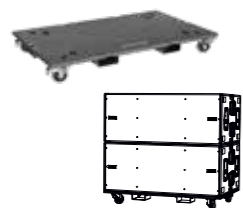

Dolly for up to 3x VIO VIO S318 stacked horizontally (wheels included).

SWK-18 KIT

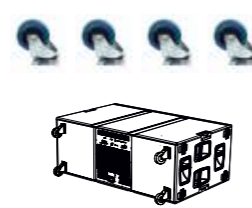

Kit consisting of 4 wheels for VIO S318 / VIO S218 back panel.

FC-V10S2



Functional Cover for 2 subs VIO S318 / VIO S218.

TC-V10S2



Transport cover for 1 VIO S318 / VIO S218.

COVERS

CABLES

DAC-100

XLR-XLR audio cable (100 cm).

DAC-500

XLR-XLR audio cable (500 cm).

DPTC-160L

PowerCON TRUE1-PowerCON TRUE1 power link cable (160cm).

DPTC-500L

PowerCON TRUE1-PowerCON TRUE1 power link cable (500cm).

DPTC-1000M

Mains PowerCON TRUE1 cable (10m). Different plugs available for several countries.

DPTC-2000M

Mains PowerCON TRUE1 cable (20m). 16A CekON

RDC-45F

RJ45 to XLR 3 poles female conversion cable, 6 cm length. The cable converts from RDNNet RJ45 to XLR.

RDC-45M

RJ45 to XLR 3 poles male conversion cable, 6 cm length. The cable converts from RDNNet RJ45 to XLR.

RJ45-RJ45-150

RJ45-RJ45 link cable (150cm) for RDNNet speakers. EtherCON connectors.

RJ45-RJ45-75

RJ45-RJ45 link cable (75cm) for RDNNet speakers. EtherCON connectors.

CAT6-CAT6-100

CAT6-CAT6 link cable (100cm) for DANTE™ AoIP and RDNNet. EtherCON connectors.

CAT6-CAT6-170

CAT6-CAT6 link cable (170cm) for DANTE™ AoIP and RDNNet. EtherCON connectors.

CAT6-CAT6-500

CAT6-CAT6 link cable (500cm) for DANTE™ AoIP and RDNNet. EtherCON connectors.

VIO S118R

VIO S118

ACTIVE 1x 18" BASS REFLEX SUBWOOFER

FLYABLE ACTIVE 1x 18" HORN LOADED SUBWOOFER



1600 W RMS SMPS DIGIPRO G4 AMPLIFIERS

SMPS WITH PFC

SYSTEM-TEST FOR QUICK DIAGNOSTICS

INTEGRATED FLYING HARDWARE ON VIO S118 (COMPATIBLE WITH VIO L210)

DESIGNED FOR MAXIMUM EFFICIENCY IN THE LOWER END

ON BOARD DELAY FOR PERFECT TIME ALIGNMENT

ON BOARD CARDIOID ARRAY CONFIGURATION PRESET

MODULAR SLOT FOR NETWORK AND DIGITAL AUDIO EXPANSION CARDS (RDNET CARD INSTALLED)

WHITE VERSION AVAILABLE

SINGLE ACTIVE SUBS

Two single 18" subwoofers featuring premium components and complete networkability, both designed to integrate VIO's line arrays with a compact solution. Horn loaded in a cabinet for flying applications. VIO S118 is the perfect low-end extension of VIO arrays whenever a particularly long-throw is needed, while bass reflex VIO S118R encompasses a powerful punch in impressively small dimensions.

	VIO S118R	VIO S118
Speaker Type	Active Bassreflex subwoofer	Active Horn-Loaded Flyable Subwoofer
Usable Bandwidth [-10dB]	32 Hz [FW 1.x] / 30 Hz [FW 2.x] - Xover Dipendent	36 Hz [FW 1.x] / 32 Hz [FW 2.x] - Xover Dipendent
Frequency Response [-6dB]	35 Hz [FW 1.x] / 33 Hz [FW 2.x] - Xover Dipendent	39 Hz [FW 1.x] / 35 Hz [FW 2.x] - Xover Dipendent
Max SPL	139 dB	139 dB
LF	1x 18"	1x 18", Neodymium
Voice Coil LF	4"	4"
Directivity	Omnidirectional	Omnidirectional
Amplifier	1600 W RMS Class-D Digipro® G4	1600 W RMS Class-D Digipro® G4
Cooling	Convection, internal fan	Convection, internal fan
Power Supply	Full-range SMPS with PFC (100V--240V-. 50-60Hz)	Full-range SMPS with PFC (100V--240V-. 50-60Hz)
Controller	DSP 32 Bit	DSP 32 Bit
AD/DA Converter	24 bit 96 kHz	24 bit 96 kHz
Limiter	Peak, RMS, Thermal	Peak, RMS, Thermal
Delay Option	0 - 9.9 ms internal steps of 0.1 ms [on-board]	0 - 9.9 ms internal steps of 0.1 ms [on-board]
Xover Frequency LF-Xover out	Selectable 60-110 Hz + Full Range (8 steps)	Selectable 60-110 Hz + Full Range (8 steps)
LF-Xover out slope	24 dB/Octave	24 dB/Octave
Signal Input	1x XLR balanced, 1x USB Data Service	1x XLR balanced, 1x USB Data Service
Signal Output	1 x XLR balanced (link or X-over)	1x XLR balanced (link or X-over)
Power Socket	1x PowerCON TRUE1 In 1x PowerCON TRUE1 Out	1x PowerCON TRUE1 In 1x PowerCON TRUE1 Out
Expansion Card	RDNet Card (1x RJ45 IN 1x RJ45 Link) Dante Card [Optional]	RDNet Card (1x RJ45 IN 1x RJ45 Link) Dante Card [Optional]
Controls	1x Input Attenuation Rotary Switch 2x Delay Rotary Encoder (9.9 ms) 1x Polarity Inversion Switch (0° or 180°) 1x Cardioid Mode Switch 1x X-Over Freq Rotary Encoder (8 steps) 1x System Auto-test	1x Input Attenuation Rotary Switch 1x Rotary Encoder (Delay 9.9 ms) 1x Polarity Inversion Switch (0° or 180°) 1x Cardioid Mode Switch 1x X-Over Freq Rotary Encoder (8 steps) 1x System Auto-test
Special Features	380V Resistant SMPS IPOS Intelligent Power-On Sequence Opto-isolated floating pre-amp System Test (transducers diagnostics)	380V Resistant SMPS IPOS Intelligent Power-On Sequence Opto-isolated floating pre-amp System Test (transducers diagnostics) NFC™ and Frontal LED Identification System
Housing	Multiplex plywood - Polyurea painting	Multiplex plywood - Polyurea painting
Handles	2x per Side, Aluminium	2x per Side, Aluminium
Pole Mount	M20 Thread	M20 Thread
Rain cover	Included	Included
Rigging Points	2x Pick Points on top to stack DRK-210	2x Pick Points on top to stack DRK-210 8x Flying Hardware (4x on top, 4x on bottom)
Width x Height x Depth	720 x 530 x 700 mm (28.34 x 20.86 x 27.56 in)	720 x 520 x 700 mm (28.34 x 20.47 x 27.56 in)
Weight	47 kg (103.62 lbs)	45.1 kg (99.42 lbs)

Equipped with a 18" woofer (4" voice coil), this bass reflex sub has been crafted to complete with impressive low-end VIO line array systems.

The front-loaded bass-reflex configuration ensures excellent performance at both close and mid-distance. Although this sub is intended for groundstack use indoor, it can also be used as a powerful low-end extension to most VIO line array systems in larger outdoor venues.



This flyable active subwoofer, equipped with a 18" neodymium transducer, has been crafted to complete the accurate and phase coherent wave front of VIO Line Arrays with impressive low-end frequencies and vigorous SPLs.

VIO S118 also features a NFC™ system and a LED on the front grille.

dBTechnologies developed a horn loaded design, while maintaining the size of a front-loaded sub cabinet, resulting in a double advantage: smaller dimension (and weight - only 45,1 kg) and a remarkable lower frequencies response even at a long distance. This makes this sub the perfect low-end extension of VIO arrays whenever a particularly long-throw is needed.

LATEST GENERATION AMPLIFIER

Both VIO S118 & VIO S118R system's acoustic engine is driven by a Digipro G4® 1600W Class D amplifier. The switched mode power supply is equipped with PFC (Power Factor Corrector) which greatly improves the efficiency of the system. This also grants a worldwide compatibility of the power supply (from 90V to 265V 50/60Hz) and limits power consumption. Furthermore, the power supply is 380V resistant, so the final amplifiers will be switched off in case of an undesired strike of 380V current, saving them from any damage.

Digipro G4 preamplifier features a slot module, equipped with a RDNet expansion card as default, allowing system monitoring and control via Aurora Net. Furthermore, the system is ready for Audinate Dante™ Expansion Card allowing integration in a digital audio network. The amplifier also allows users to run a real-time test on transducers, both remotely via Aurora Net, or directly on the amplifier module.

The amp module features an on board attenuation control and a delay module allowing to reach a max 9.9 ms delay with 0.1 ms steps. The on board cardioid preset process the sound of the backward sub in cardioid configurations.



S118's cabinet is equipped with integrated hardware allowing 1 or more subs to be flown in a sub array or on the top of a VIO L210 array. Furthermore the subwoofer can be flown with DRK-210 flybar in inverted orientation to create flown cardioid arrays. With FSA-VIOL210 adapter it is possible to attach VIO L210, or alternatively VIO L208 with AF-VIO1 adapter frame.

Groundstacking line arrays on VIO S118 is possible thanks to dedicated accessories.



TRANSPORT & INSTALLATION ACCESSORIES

AF-VIO1	DO-VIOS118	DSA-VIOL208	FSA-VIOL210	GSA-VIOL210	SWK-18 KIT	FC-VIOS1	TC-VIOS1
Adapter frame for flying VIO L208 under VIO S118 / VIO L210 and groundstacking VIO L208/L210 on any VIO sub.	Dolly for up to 3x VIO S118 / S118R.	Groundstack adapter for VIO L208 on VIO S118 and S118R.	Adapter to fly VIO L210 under flown VIO S118.	Adapter to stack VIO L210 on VIO S118.	Kit consisting of 4 wheels for VIO S118R back panel.	Functional cover for 2 VIO S118R / VIO S118.	Transport cover for VIO S118R.

COVERS

CABLES

DAC-70	XLR-XLR audio cable (70 cm).	RDC-45F	RJ45 to XLR 3 poles female conversion cable, 6 cm length. The cable converts from RDNet RJ45 to XLR.
DAC-500	XLR-XLR audio cable (500 cm).	RDC-45M	RJ45 to XLR 3 poles male conversion cable, 6 cm length. The cable converts from RDNet RJ45 to XLR.
DCK-27T	Cable-Set containing 2x DAC-70 and 2x DPTC-70L.	RJ45-RJ45-150	RJ45-RJ45 link cable (150cm) for RDNet speakers. EtherCON connectors.
DPTC-70L	PowerCON TRUE1-PowerCON TRUE1 power link cable (70cm).	RJ45-RJ45-75	RJ45-RJ45 link cable (75cm) for RDNet speakers. EtherCON connectors.
DPTC-160L	PowerCON TRUE1-PowerCON TRUE1 power link cable (160cm).	CAT6-CAT6-100	CAT6-CAT6 link cable (100cm) for DANTE™ AoIP and RDNet. EtherCON connectors.
DPTC-500L	PowerCON TRUE1-PowerCON TRUE1 power link cable (500cm).	CAT6-CAT6-170	CAT6-CAT6 link cable (170cm) for DANTE™ AoIP and RDNet. EtherCON connectors.
DPTC-1000M	Mains PowerCON TRUE1 cable (10m). Different plugs available for several countries.	CAT6-CAT6-500	CAT6-CAT6 link cable (500cm) for DANTE™ AoIP and RDNet. EtherCON connectors.
DPTC-2000M	Mains PowerCON TRUE1 cable (20m). 16A CekON.		



Speaker Type	Active Bassreflex Subwoofer
Usable Bandwidth [-10dB]	36 Hz - (user frequency LPF)
Frequency Response [-6dB]	40 Hz - (user frequency LPF)
Max SPL	134 dB
LF	1x 15"
Voice Coil LF	4"
Directivity	Omnidirectional
Amplifier	900 W RMS Class-D Digipro® G3
Cooling	Convection
Power Supply	Auto-range SMPS
Controller	DSP 32 bit
AD/DA Converter	24 bit/96 kHz
Limiter	Peak, RMS, Thermal
Delay Option	0-9.9 ms internal steps of 0.1 ms
Xover Frequency LF-Xover out	Selectable 70-105 Hz + Full Range (8 steps)
LF-Xover out slope	24 dB/Octave
Signal Input	1 x XLR balanced, 1 x RJ45 Link (RDNet) 1x USB Data Service
Signal Output	1x XLR balanced, 1 x RJ45 Link (RDNet)
Power Socket	1x PowerCON TRUE1 In 1x PowerCON TRUE1 Out
Controls	1x Input Sensitivity Rotary Encoder 1x X-over Selection Rotary Encoder 1x Delay Selection Encoder 1x Polarity Selection Switch 1x X-out Mode Selection Switch 1x On-LED 1x Status-LED 1x Signal-LED 1x Limiter-LED 3x RDNet Status-LED
Special Features	Opto-isolated floating pre-amp
Housing	Multiplex plywood - Polyurea painting
Pole Mount	1x M20 on Top, 1x M20 on Right Side
Handles	1x Side, Aluminium
Rigging Points	16x M10
Width x Height x Depth	650 x 420 x 550 mm (25.6 x 16.5 x 21.7 in)
Weight	32.8 kg (72.3 lbs)

FLYABLE SINGLE 15" SUBWOOFER

900W RMS SMPS AMPLIFIER

HORIZONTAL OR VERTICAL USE

COMPLETE NETWORKABILITY VIA RDNET



Driven by a Digipro G3 900 W RMS amp, and provided with the advanced VIO DSP, the acoustic engine is enabled to impressive SPLs and complete networkability and remote control in real time via RDNet protocol and Aurora Net software.

For ease of use, basic DSP functions such as delay, crossover frequency and low-pass filters can be accessed via onboard controls on the back panel.

The most compact subwoofer in VIO family, VIO S115 is a single 15" cabinet designed as the perfect low-end complement for VIO X full range PAs, both in stacked or flown configurations.

VIO S115 is equipped with a premium 15-inch neodymium woofer loaded in a bass-reflex configuration. Its limited size and reduced weight make it the most compact cabinet of the VIO family, designed as a solution for low frequencies in sound reinforcement systems with full range VIO X tops, especially for the very compact VIO X205 and VIO X206.



M10 threads and dedicated brackets and flybars ease installation or flown set ups, and many more configurations that will suit any installation requirement.

The single DRK-1 and the double DRK-2 flybars allow users to create sub arrays, double sub arrays, or sub + top arrays with VIO X206 used in line array mode.

The cabinet design also features M20 pole mounts on the top and side, so it is possible for users to set up stacked PAs with vio x tops using the sub vertically or horizontally.



ACCESSORIES

DRK-1



Flybar for VIO S115

DRK-2



Double-hanging flybar for VIO S115

TC-S115



Transport cover for VIO S115

LP-4



Link plate for VIO S115

LP-5



Link plate for VIO X206 and VIO S115

RC-1



Rain cover for VIO S115

CONSTANT CURVATURE ARRAY SPEAKERS

VIO C is a complete series of 2-way active line-source speakers designed to upgrade the arrayable loudspeaker concept to a brand-new level.

Based on the concept of constant curvature array, VIO C systems have been designed to create both vertical or horizontal line-source arrays.

VIO C's peculiar acoustic design, together with its agile rigging system, and complete networkability, makes countless configurations possible, allowing for the most flexible coverage options as well as the powerful and pure acoustic performance that distinguishes all VIO cabinets.





2-WAY ACTIVE LINE-SOURCE SPEAKERS

Available in 3 different models, respectively equipped with 12", 15", and 2x 12" woofers, VIO C allows users to design scalable PAs for the broadest range of venues and applications, from installed PA systems to sound reinforcement for live music and touring. The smoothest deployment is granted by the exclusively designed rigging system based on quick-release plates, allowing for easy and rapid set-up operations.



2-WAY ACTIVE LINE-SOURCE SPEAKERS

NEODYMIUM COMPONENTS

1600W RMS DIGIPRO® G4 AMP TECHNOLOGY

ADVANCED DSP FEATURING LINEAR PHASE FIR FILTERS

HORIZONTAL SCALABLE LINE SOURCE AND VERTICAL CONSTANT CURVATURE ARRAY CONFIGURATION POSSIBLE

EXCLUSIVELY DESIGNED WAVEGUIDE FOR MAXIMUM HF DIRECTIVITY CONTROL

OLED USER-FRIENDLY INTERFACE

FULLY NETWORKABLE VIA AURORA NET

FULL RANGE SMPS WITH PFC

ACCESSORIES COMPATIBLE FOR ALL MODELS

	VIO C12	VIO C15	VIO C212
Speaker Type	2 Way Active Cluster Loudspeaker	2 Way Active Cluster Loudspeaker	2 Way Active Cluster Loudspeaker
Usable bandwidth [-10dB]	52 - 19,000 Hz	42 - 19,000 Hz	46 - 19,000 Hz
Frequency Response [-6dB]	55 - 18,000 Hz	46 - 18,000 Hz	51 - 18,000 Hz
Max SPL	139 dB	140 dB	141 dB
HF	1x 1.4"	1x 1.4"	1x 1.4"
Voice Coil HF	3" Neodymium	3" Neodymium	3" Neodymium
LF	1x 12"	1x 15"	2x 12"
Voice Coil LF	3.5" Neodymium	3.5" Neodymium	3" Neodymium
Directivity (HxV)	22.5° x 55° (+20°/-35°)	22.5° x 45° (+15°/-30°)	22.5° x 55° (+20°/-35°)
Amplifier	1600 W RMS Class-D Digipro® G4	1600 W RMS Class-D Digipro® G4	1600 W RMS Class-D Digipro® G4
Cooling	Convection + Internal Fan	Convection + Internal Fan	Convection + Internal Fan
Power Supply	Full-range SMPS with PFC	Full-range SMPS with PFC	Full-range SMPS with PFC
Controller	DSP 32 bit	DSP 32 bit	DSP 32 bit
AD/DA Converter	24 bit/96 kHz	24 bit/96 kHz	24 bit/96 kHz
Limiter	Dual Active Peak, RMS, Thermal	Dual Active Peak, RMS, Thermal	Dual Active Peak, RMS, Thermal
Processing	FIR Linear Phase Filters	FIR Linear Phase Filters	FIR Linear Phase Filters
Signal Input	1x XLR female, balanced 1x USB Data Service	1x XLR female, balanced 1x USB Data Service	1x XLR female, balanced 1x USB Data Service
Signal Output	1x XLR male, balanced	1x XLR male, balanced	1x XLR male, balanced
Expansion Card	RDNet Card (1x RJ45 Link IN, 1x RJ45 Link) Dante Card [Optional]	RDNet Card (1x RJ45 Link IN, 1x RJ45 Link) Dante Card [Optional]	RDNet Card (1x RJ45 Link IN, 1x RJ45 Link) Dante Card [Optional]
Power Socket	1x PowerCON TRUE1 In 1x PowerCON TRUE1 Out	1x PowerCON TRUE1 In 1x PowerCON TRUE1 Out	1x PowerCON TRUE1 In 1x PowerCON TRUE1 Out
Controls	OLED Display + rotative knob w/switch	OLED Display + rotative knob w/switch	OLED Display + rotative knob w/switch
Special Features	IR Positioning System on top and both sides Opto-isolated floating pre-amp 380V Resistant SMPS IPOS Intelligent Power-On Sequence Inclinometer	IR Positioning System on top and both sides Opto-isolated floating pre-amp 380V Resistant SMPS IPOS Intelligent Power-On Sequence Inclinometer	IR Positioning System on top and both sides Opto-isolated floating pre-amp 380V Resistant SMPS IPOS Intelligent Power-On Sequence Inclinometer
Housing	Wooden Cabinet, Polyurea painting	Wooden Cabinet, Polyurea painting	Wooden Cabinet, Polyurea painting
Handles	2 on back + 1x side	2 on back + 1x side	2 on back + 1x side
Rain Cover	Included	Included	Included
Rigging Points	Corner quick link (1x LP-1 included)	Corner quick link (1x LP-1 included)	Corner quick link (1x LP-1 included)
Pole Mount	Ø36 mm	Ø36 mm	Ø36 mm
Width x Height x Depth	379 x 787 x 495 mm (14.92 x 30.98 x 19.48 in)	436 x 892 x 630 mm (17.16 x 35.11 x 24.80 in)	379 x 1132 x 495 mm (14.92 x 44.56 x 19.48 in)
Weight	31.8 kg (70.1 lbs)	40.6 kg (89.5 lbs)	41.7 (91.9 lbs)

UNIQUE ACOUSTIC DESIGN

Equipped with premium neodymium components, every model in VIO C series features a waveguide, whose design is based on that of VIO line array systems, plus a vertical asymmetrical horn.

This peculiar acoustic design enables the system to deliver the most constant and precise dispersion pattern.

Any single VIO C enclosure precisely provides a horizontal coverage of 22.5 ° since the speaker has been conceived in order to work side by side with other units.

When matching companion cabinets, users can easily set up scalable horizontal or vertical clusters, adapting the VIO C to the venue and application in use.



VIO C clusters can be rapidly assembled thanks to the LP-1, a metal link plug accessory (1 is included in each VIO C unit) which links the rigging points placed on the corners of each cabinet. A very user-friendly device allowing to secure two units side by side in seconds.

The whole series is equipped with the latest generation 1600 W RMS Class D Amp module Digipro G4, the same amp technology driving top-notch VIO family systems. The 380 V shock-resistant SMPS features PFC, allowing the system to run smoothly in any country in the world, regardless of the input voltage.

Complete networkability functions are granted by RDNet, allowing for real-time monitoring and control of the system in use via Aurora Net. Each VIO C unit is equipped by default with a modular RDNet card slot. Nevertheless, the preamplifier is ready for future upgrades with Audinate Dante card.

The on-board OLED display shows the pairing status of the cluster in use and allows to manually get some of the DSP functions.



Enclosures are made of plywood reinforced by a black polyurea finish. A removable raincover is included in each cabinet which is also equipped with 2 side and 2 back handles easing transport and setup.



ACCESSORIES

DRK-C



Flybar for hanging 2 VIO C speakers side by side.

DRKL-3



Link for DRK-C when flying 3 VIO C speakers or 2 rows of 3 VIO C speakers in horizontal array.

DRKL-4



Link for DRK-C when flying 4 VIO C speakers or 2 rows of 4 VIO C speakers in horizontal array.

DRK-CCA



Flybar for up to 4 VIO C12 or 4 VIO C15 in vertical array configuration.

LP-1



Link plug for VIO C Series.

TC-VIO C12, 15, 212



Transport cover available for VIO C12, VIO C15 and VIO C212.

MAXIMUM FLEXIBILITY

Featuring an exclusively designed waveguide as well as an asymmetrical horn, any single VIO C enclosure precisely provides a horizontal 22.5° angle coverage pattern. When matching companion cabinets, users can easily set up scalable horizontal clusters, adapting the VIO C to the venue and application in use. Thus, a 3-cabinet side-by-side configuration delivers roughly a 67° horizontal pattern, a 4-cabinet cluster reaches a 90° horizontal angle, and so forth.

VIO C series scalability goes far beyond that. Thanks to the acoustic design allowing for asymmetrical vertical dispersion, users can easily head-stack a second set of VIO C12 or VIO C15 speakers on top, creating two rows of horizontal clusters, for the great benefit of sound pressure level. The vertical beam is adjustable via software, in order to adapt the coverage to the venue.

IR POSITIONING SYSTEM

Infrared ports are placed on top and both sides of each cabinet so that the speakers can recognize the size and configuration of the system when linked together horizontally or vertically. The on-board OLED display shows the pairing status of the cluster in use.

VIO C Series

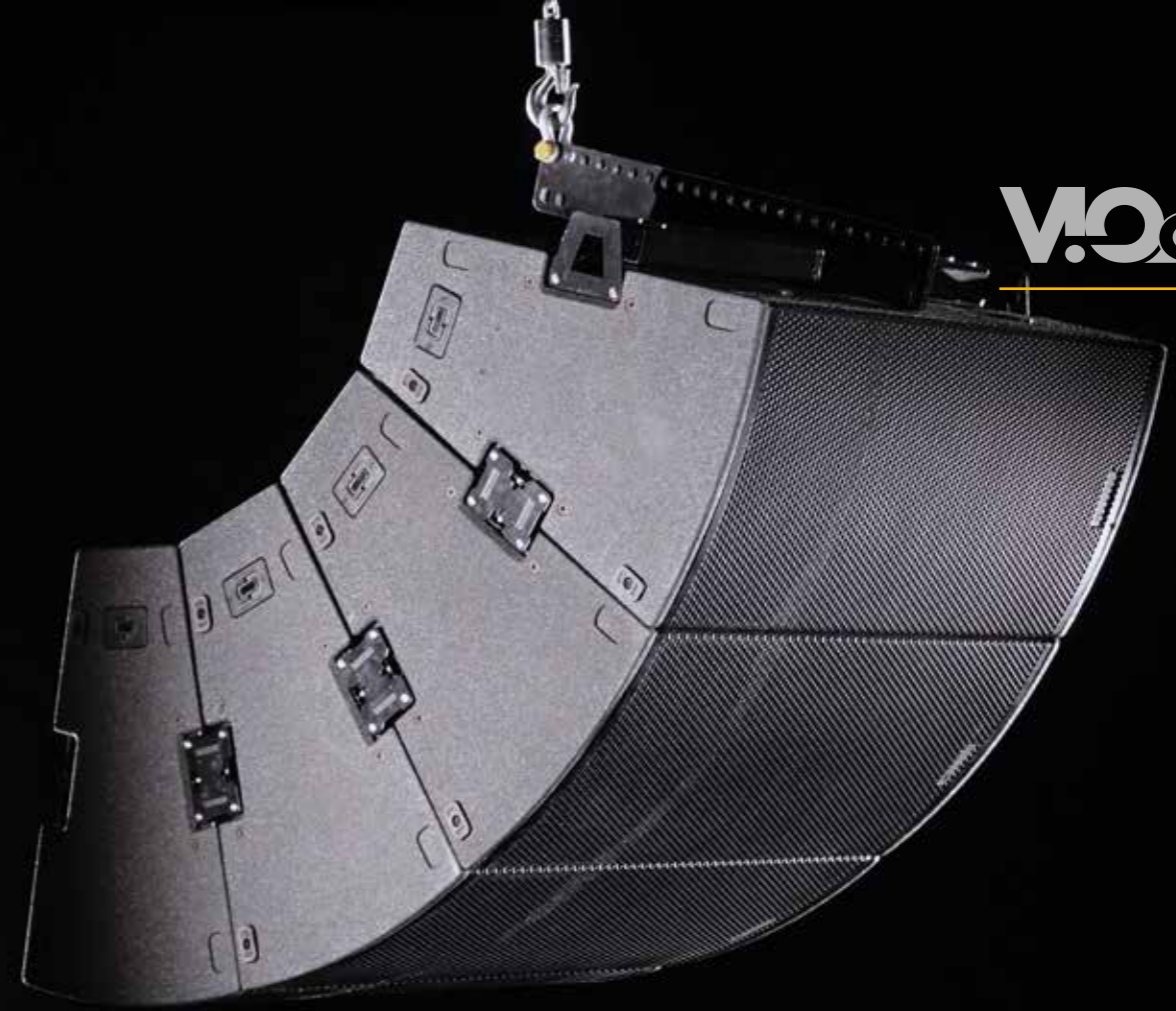

A set of accessories allows for multiple configurations.

The DRK C flybar is designed for horizontal clusters in combination with DRK L3 or DRKL4 link bars, depending on the number of speakers in use.

The DRK CCA fly bar has been designed for vertical array in a constant curvature configuration: up to 4 C12s or 4 C15s are flyable in this mode.



POINT SOURCE SPEAKERS

Boasting an impressive feature set comprising premium neodymium components, impressive SPL, advanced DSP featuring Linear Phase FIR filters, complete networkability via RDNNet protocol, multifunctional multiplex housings equipped with rigging points and rails, VIO X is the perfect point source completion for VIO family in a wide range of applications.





2-WAY ACTIVE LOUDSPEAKER SERIES

3 MODELS: 10, 12 AND 15"

NEODYMIUM COMPONENTS

DIGIPRO G3 AMP 900W RMS

ADVANCED DSP FEATURING
LINEAR PHASE FIR FILTERS

FULLY NETWORKABLE VIA AURORA NET

ON BOARD HQ AND HPF DSP PRESETS

POINT-SOURCE COMPLETION

dBTechnologies presents VIO X, an original series of professional active 2-way speakers combining impressive output, advanced DSP features and complete networkability via Aurora Net software. Conceived as a point-source completion for the VIO family, the new VIO X series provides in fact a broad spectrum of professional applications as well as flexible configuration options.

	VIO X10	VIO X12	VIO X15
Speaker Type	2 Way Active Loudspeaker	2 Way Active Loudspeaker	2 Way Active Loudspeaker
Usable bandwidth [-10dB]	73 - 21,400 Hz [FW 1.x] 65 - 21,400 Hz [FW 2.x]	62 - 22,000 Hz [FW 1.x] 60 - 22,000 Hz [FW 2.x]	55 - 22,000 Hz [FW 1.x] 50 - 22,000 Hz [FW 2.x]
Frequency Response [-6dB]	82 - 20,000 Hz [FW 1.x] 70 - 21,400 Hz [FW 2.x]	79 - 21,000 Hz [FW 1.x] 65 - 21,000 Hz [FW 2.x]	72 - 21,000 Hz [FW 1.x] 60 - 21,000 Hz [FW 2.x]
Max SPL	130 dB	132 dB	133.5 dB
HF	1x 1"	1x 1.4"	1x 1.4"
Voice Coil HF	1.75"	2.5" Neodymium	2.5" Neodymium
LF	1x 10"	1x 12"	1x 15"
Voice Coil LF	2.5" Neodymium	3" Neodymium	3" Neodymium
Directivity (HxV)	90° x 40°	60° x 40°	60° x 40°
Horn	Rotatable Horn	Rotatable Horn	Rotatable Horn
Amplifier	900 W RMS Class-D Digipro® G3	900 W RMS Class-D Digipro® G3	900 W RMS Class-D Digipro® G3
Cooling	Convection	Convection	Convection
Power Supply	Auto-range SMPS	Auto-range SMPS	Auto-range SMPS
Controller	DSP 28/56 bit	DSP 28/56 bit	DSP 28/56 bit
AD/DA Converter	24 bit/48 kHz	24 bit/48 kHz	24 bit/48 kHz
Limiter	Peak, RMS, Thermal	Peak, RMS, Thermal	Peak, RMS, Thermal
Processing	FIR Linear Phase Filters	FIR Linear Phase Filters	FIR Linear Phase Filters
Signal Input	1x XLR balanced, 1x RJ45 Link (RDNet) 1x USB Data Service	1x XLR balanced, 1x RJ45 Link (RDNet) 1x USB Data Service	1x XLR balanced, 1x RJ45 Link (RDNet) 1x USB Data Service
Signal Output	1x XLR balanced, 1x RJ45 Link (RDNet)	1x XLR balanced, 1x RJ45 Link (RDNet)	1x XLR balanced, 1x RJ45 Link (RDNet)
Power Socket	1x PowerCON TRUE1 In 1x PowerCON TRUE1 Out	1x PowerCON TRUE1 In 1x PowerCON TRUE1 Out	1x PowerCON TRUE1 In 1x PowerCON TRUE1 Out
Controls	1x Rotary Encoder (8x EQ, HPF presets) 1x Input sensitivity potentiometer 1x Mic / line switch	1x Rotary Encoder (8x EQ, HPF presets) 1x Input sensitivity potentiometer 1x Mic / line switch	1x Rotary Encoder (8x EQ, HPF presets) 1x Input sensitivity potentiometer 1x Mic / line switch
Special Features	Opto-isolated floating pre-amp	Opto-isolated floating pre-amp	Opto-isolated floating pre-amp
Housing	Wooden Cabinet, Polyurea painting	Wooden Cabinet, Polyurea painting	Wooden Cabinet, Polyurea painting
Handles	1x (top)	1x (top), 2x (side)	1x (top), 2x (side)
Wedge Angle	Monitor use 50°	Monitor use 50°	Monitor use 50°
Rigging points	12x M10 Thread + 4x Fast lock pins	12x M10 Thread + 4x Fast lock pins	12x M10 Thread + 4x Fast lock pins
Pole Mount	Ø36 mm	Ø36 mm	Ø36 mm
Width x Height x Depth	280 x 550 x 375 mm (11.02 x 21.65 x 14.76 in)	340 x 650 x 445 mm (13.38 x 25.5 x 17.51 in)	400 x 750 x 475 mm (15.74 x 29.52 x 18.7 in)
Weight	16.6 kg (36.59 lbs)	20.7 kg (45.63 lbs)	25.4 kg (55.99 lbs)

PROFESSIONAL & FLEXIBLE



The series encompasses 3 models: all equipped with a specially designed rotatable horn facilitating a clear and constant directivity.



VIO X10, featuring 1x 10" woofer (2.5 v.c) and a 1" compression driver (1.75" v.c.)



VIO X12, featuring 1x 12" woofer (3" v.c.) and 1x 1.4" compression driver (3" v.c.)



VIO X15, featuring 1x 15" woofer (3" v.c) and 1x 1.4" compression driver (3" v.c.)

All cabinets are powered by on board Digipro G3 900 W RMS providing majestic sound pressure levels in compact size and very limited weight. Advanced sound processing featuring Linear Phase FIR Filters allows VIO Xs to deliver an extremely coherent audio performance, standing out for its intelligibility and clarity from every listening position.



A feature-mix boosting high-end audio performance as well as advanced versatility. As a matter of facts, VIO X cabinets serve impressively as a stand alone PA system that can be stacked, flown or wall-mounted, as a full range PA or in combination with VIO S118 and VIO 118R subwoofers, but also act as the perfect side-fill, delay or stage monitoring system in larger VIO sound reinforcement applications.

The robust wooden enclosure allows horizontal use for monitoring purposes and is provided with a 36mm pole mount, and rigging points facilitating fixed installations with dedicated vertical and horizontal brackets.



On board presets let users adapt High Pass Filters to the chosen application, as well as dedicated EQ presets for Wedge or Fullrange mode. Last but not least, VIO X is equipped with RDNet port allowing monitoring and full remote control in real time via Aurora Net software (Windows and Mac).

ACCESSORIES

RC-M1	WB-VIOX10H	WB-VIOX12H	WB-VIOX15H	WB-VIOX10V	WB-VIOX12V	WB-VIOX15V	FC-VIOX10, X12, X15
Amplifier magnetic rain cover.	Horizontal wall bracket for VIO X10.	Horizontal wall bracket for VIO X12.	Horizontal wall bracket for VIO X15.	Vertical bracket for VIO X10. 36mm pole mount included.	Vertical bracket for VIO X12. 36mm pole mount included.	Vertical bracket for VIO X15. 36mm pole mount included.	Functional cover available for VIO X10, VIO X12 and VIO X15.



3 WAY TRI-AMPED ACTIVE POINT SOURCE

FLYABLE WITH ACCESSORIES

COAXIAL MID-HIGH TRANSDUCER

NEODYMIUM COMPONENTS

1400 W RMS DIGIPRO G4 AMP TECHNOLOGY

LINEAR PHASE FIR FILTERS

OUTSTANDING SPL UP TO 138 DB

FULL-RANGE SMPS WITH PFC

SYMMETRIC DESIGN FOR VIO X310

MODULAR SLOT FOR NETWORK AND DIGITAL AUDIO EXPANSION CARDS - RDNET CARD INSTALLED

EXTENDED LOW-END RESPONSE FOR VIO X315

SYSTEM TEST FOR QUICK TRANSDUCERS DIAGNOSTICS

THE 3-WAY TRI-AMPED DESIGN

Introducing VIO X300 series, the evolution of our premium line VIO X: powerful, tour-grade, three-way tri-amped point source speakers for public address in large venues.

VIO X310 and VIO X315 are both self-powered point source speakers capable of delivering outstanding sound pressure levels for the size, and they render stellar acoustic performance thanks to premium components, a three-way tri-amplified design and state of the art electronics.

	VIO X310	VIO X315
Speaker Type	3 Way Active Loudspeaker	3 Way Active Loudspeaker
Usable bandwidth [-10dB]	53 - 19,800 Hz	34 - 19,200 Hz
Frequency Response [-6dB]	57 - 19,200 Hz	37 - 18,000 Hz
Max SPL	138 dB	137 dB
HF/MF	1x 1.4"	1x 1.4"
Voice Coil HF/MF	4" 2.5" v.c. Coaxial Neo	4" 2.5" v.c. Coaxial Neo
LF	2x 10"	1x 15"
Voice Coil LF	2.5" v.c Neo	4" v.c Neo
Directivity	90° x 40° [H x V]	90° x 50° - 5° tilted down [H x V]
Amplifier	1400 W RMS Class-D Digipro® G4	1400 W RMS Class-D Digipro® G4
Cooling	Convection	Convection
Power Supply	Full range SMPS with PFC	Full range SMPS with PFC
Controller	DSP 32 bit	DSP 32 bit
AD/DA Converter	24 bit/96 kHz	24 bit/96 kHz
Limiter	Peak, RMS, Thermal	Peak, RMS, Thermal
Processing	FIR Linear Phase Filters	FIR Linear Phase Filters
Signal Input	1 x XLR balanced, 1 x RJ45 Link (RDNet), 1x USB (Data Service)	1 x XLR balanced, 1 x RJ45 Link (RDNet), 1x USB (Data Service)
Signal Output	1x XLR balanced, 1 x RJ45 Link (RDNet)	1x XLR balanced, 1 x RJ45 Link (RDNet)
Power Socket	1x PowerCON TRUE1 In 1x PowerCON TRUE1 Out	1x PowerCON TRUE1 In 1x PowerCON TRUE1 Out
Controls	1x input Rotary Encoder (8x presets) 1x Ready LED 1x Mute/Prot LED 1x Signal LED 1x Limiter LED 1x Frontal LED 1x Button and 1x LED System Test	1x input Rotary Encoder (8x presets) 1x Ready LED 1x Mute/Prot LED 1x Signal LED 1x Limiter LED 1x Frontal LED 1x Button and 1x LED System Test
Housing	Wooden Cabinet, Polyurea painting	Wooden Cabinet, Polyurea painting
Handles	1x on top / 1x on bottom	3 (1x side, 1 on top)
Rigging points	flyable with bracket	12x M10 Thread
Pole mount	/	D36mm
Width x Height x Depth	300 x 780 x 430 mm (11.8 x 30.7 x 16.9 in)	420 x 820 x 520 mm (16.5 x 32.3 x 20.5 in)
Weight	28 kg (61.5 lbs)	39.5 kg (87.1 lbs)



3-WAY TRI-AMPED DESIGN

The MF-HF coaxial component mounted in both VIO X310 and VIO X315 utilize the same transducer used in the VIO L1610 line array module: it's a 4" voice coil plus 2.5" voice coil coaxial driver, an heavy-

duty and high-fidelity transducer reproducing from 500Hz up.

When it comes down to detailed mid-range reproduction, a compression driver diaphragm is much quicker and more accurate than a similar sized woofer. Furthermore, because of the compact dimensions, this content

can be easily dispersed through a horn, just like you would do with an HF driver, for improved control over the sonic pattern.

These characteristics result in an incredibly faithful and meticulous reproduction of the most critical frequency range, essential for clear-cut intelligible vocals and instrument separation in your mix.

Since a great portion of the frequency content is horn loaded, not only is the sound pressure level impressive due to the acoustic loading, but also directivity control is maximized.

Last but not least, the sum of all these acoustic design choices combined with cutting edge class-D amplifiers and DSP processing result in remarkable sound pressure levels, as high as 137dB.

The two speakers share the same coaxial MF-HF transducer but differ in size due to the different components handling the low-end reproduction.

VIO X310 is equipped with 2x 10" neodymium woofers in a dipole configuration, so the speaker benefits from all the advantages of this arrangement such as a very prominent directivity control for low-mids and a precise, fast, and extended response of the bottom end.



The Coaxial mid-high frequency compression driver is mounted behind a 90° by 40° rotatable horn, and all the components are arranged around the center of this point source, resulting in a symmetrical dispersion.



VIO X315 is equipped with a single high performance 15" neodymium woofer, capable of providing loud, precise, wide band performances, with no compromises. The goal was to develop a real full-range PA system, with an astounding wide frequency response, reaching as low as 37Hz.

In this model, the mid-hi coaxial transducer is placed behind a 90°x50° horn which has been designed with a slight tilt downwards (around 5°) to optimize the coverage in average venues.

ELECTRONICS AND PROCESSING

Modern tour requirements include a very reliable design and extended use of technology to adapt the PA to any venue: VIO X300 series takes advantages of the entire range of available upgrades derived from the VIO series development in the last years.

VIO X300 makes the most of the acoustic design, delivering an astounding SPL and allowing for full bandwidth capabilities.

All of the above great advantages come with the ease of use of any other conventional active point source speaker.

Thanks to specific brackets and M10 threads, VIO X300 series can be utilized as fills in larger setups, such as a full range under balcony or delay system in fixed installations. Equally VIO X300 can be deployed as a compact, complete standalone 3-way system for any audience. Lastly, VIO X300 can cover large, open air sound reinforcement setups, serving as high SPL fills, or powerful standalone PAs for the most demanding applications.



The series is equipped with a 1400W RMS Class-D Digipro G4 power amplifier, a 4-channel amplifier able to drive each component individually, with dedicated FIR filters enabled sound processing for low, mid and high frequencies. This amp has been specially designed for VIO X300 series and allows for complete networkability via Aurora Net thanks to RDNet ports. A modular card slot is ready for future I/O and remote-control upgrades.

A Power Factor Corrections enabled PSU ensures extreme adaptability to any environment while an integrated System Test checks for any possible transducer failure during the show. Also, a frontal LED light will always allow to determine the position of any remote controlled VIO X3 enclosure at any time via Aurora Net Software, the same suite used to access the speakers' advanced processing instances, such as delay up to 560ms and up to 16 EQ filters.

ACCESSORIES

HB-3X10



Horizontal bracket for VIO X310.

RC-X3



Rain Cover for VIO X310 and VIO X315.

TC-VIOX310



Transport Cover for VIO X310.

TC-VIOX315



Transport Cover for VIO X315.

VB-3X10



Vertical Bracket for VIO X310.



60°x90° VERSION
WITH ROTATABLE HORN

ARRAYABLE 100°x15° VERSION
WITH WAVEGUIDE



900W RMS ACTIVE 2-WAY SPEAKER

HF 1x 1" NEO - LF 2x 6.5"

COMPLETE NETWORKABILITY VIA RDNET

MAXIMUM VERSATILITY IN TOUR GRADE APPLICATIONS OR FIXED INSTALLATIONS

DSP PRESET SWITCH ON BOARD TO MATCH THE COVERAGE PATTERN IN USE

WIDE ACCESSORIES CHOICE FOR MULTIPLE APPLICATIONS

IN A CLASS OF ITS OWN

VIO X206 not only packs the best of the VIO X line's sonic performance into an ultra-compact cabinet but also brings versatility to a new level by serving as both a point source speaker and a line array system. The ultimate solution for complementing VIO PA systems and setting up compact high-performance stand-alone systems, meeting the requirements of both the production and integration world.

Speaker Type	2 Way Active Loudspeaker
Usable bandwidth [-10dB]	66 - 19,500 Hz / 66 - 18,000 Hz [VIO X206-100]
Frequency Response [-6dB]	70 - 18,000 Hz / 70 - 17,500 Hz [VIO X206-100]
Max SPL	131 dB
HF	1x 1" exit Neodymium
Voice Coil HF	1.75"
LF	2x 6.5"
Voice Coil LF	1.75"
VIO X206 Directivity	60° x 90° [rotatable horn]
VIO X206-100 Directivity	100° x 15° [H x V]
Amplifier	900 W RMS Class-D Digipro® G3
Cooling	Convection
Power Supply	Auto-range SMPS
Controller	DSP 32 bit
AD/DA Converter	24 bit/96 kHz
Limiter	Peak, RMS, Thermal
Processing	FIR Linear Phase Filters
Signal Input	1x XLR balanced, 1x RJ45 Link (RDNet) 1x USB Data Service
Signal Output	1x XLR balanced, 1x RJ45 Link (RDNet)
Power Socket	1x PowerCON TRUE1 In 1x PowerCON TRUE1 Out
Controls	1x Input Sensitivity Rotary Encoder (10x presets) 1x Horn Model Selection Switch 1x HF Correction Switch 1x On-LED 1x Status-LED 1x Signal-LED 1x Limiter-LED 3x RDNet Status-LED
Housing	Wooden Cabinet, Polyurea painting
Handles	2 Integrated
Rigging points	2x M10 Threaded Nut (on top and bottom)
Width x Height x Depth	210 x 650 x 270 mm (8.3 x 25.6 x 10.6 in)
Weight	17.3 kg (38.14 lbs)

UNIQUE ACOUSTIC DESIGN



VIO X206
rotatable horn version
90° x 60° dispersion

VIO X206 is equipped with 2x 6.5" neodymium transducers, and a 1" compression driver, driven by a Digipro class D 900 Watts RMS power amplifier, which, just like any other product in the VIO family, is equipped with RDNet, allowing for remote control with Aurora net software.

POINT SOURCE OR LINE ARRAY DISPERSION

The system is available in 2 models providing different coverage patterns.

VIO X206 features a horn allowing for a 60x90° dispersion. VIO X206-100, instead, features a waveguide providing a 100x15° dispersion, allowing the system to operate in line array mode.

Both VIO X206 horn and VIO X206-100 waveguide are removable, meaning that users can easily replace them, adapting their VIO X206 systems to the venue and application in use.

A firmware preset button on board optimizes the behavior of the DSP to the application in use.



VIO X206-100
arrayable version with waveguide
100° x 15° dispersion



LINE ARRAY MODE

VIO X206 100x15° version is suitable to be mounted in line array mode thanks to LP-5 link plate, which also enables users to set different splay angles. The same accessory allows to hook up VIO S115 flyable subwoofers to the array as well. In addition to the standard DRK-1 flybar for single VIO X206 arrays, the dual DRK-2 flybar allows flying at the same time 2 arrays of VIO X206, or VIO S115 subs, or even tops and subs together.

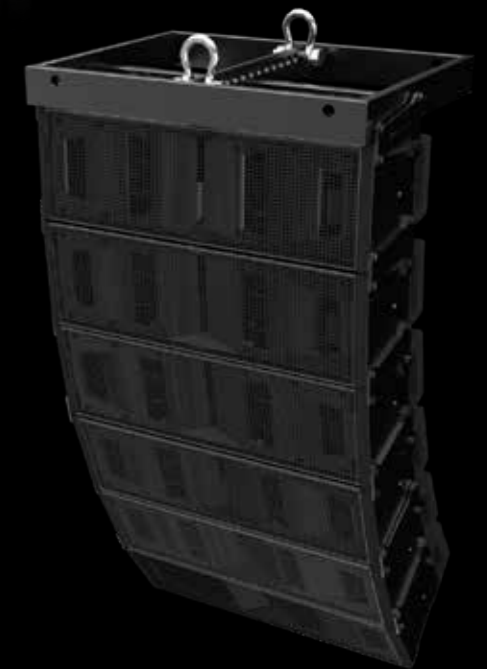

ACCESSORIES

- | | | | |
|----------------------|--|--------------------------------|----------------------------------|
| DRK-1 | DRK-2 | FC-206 | HB-2X6 |
| | | | |
| Flybar for VIO X206. | Double-hanging flybar for VIO X206 and VIO S115. | Functional cover for VIO X206. | Horizontal bracket for VIO X206. |

ACCESSORIES

- | | | | | | | | |
|-------------------------------|-----------------------------|--------------------------|------------------------------|---------------------------------------|--------------------------|-------------------------------------|--------------------------------|
| HK-6090 | HK-15100HW | LP-2 | LP-3 | LP-5 | RC-1 | SA-2X6 | VB-2X6 |
| | | | | | | | |
| 60x90° horn kit for VIO X206. | Waveguide kit for VIO X206. | Link plate for VIO X206. | 60° link plate for VIO X206. | Link plate for VIO X206 and VIO S115. | Rain cover for VIO X206. | Speaker stand adapter for VIO X206. | Vertical bracket for VIO X206. |



ENHANCED SETUP SPEED

With SB-2X6, configuring precise angles for a line array setup takes just seconds. This accessory guarantees optimal sound dispersion by adapting the shape of the array to any venue. With SB-2X6 you can unlock the capabilities of DRK-2X6 and DT-2X6 for VIO X206 speakers.

The DRK-2X6 offers flexibility for any application, making it an indispensable accessory for professional installations and touring applications. Works both for Line Array Configurations and Groundstack ones.



The DT-2X6 touring cart is built to stack up to 6x VIO X206 speakers securely plus DRK-2X6 flybar, providing unmatched convenience during transport.

SB-2X6, DT-2X6, and DRK-2X6 - each crafted with precision to enhance your sound, simplify your setup, and unleash VIO X206 full potential.

ACCESSORIES

DT-2X6



Touring cart for stacking up to 6 VIO X206. Only with SB-2X6

DRK-2X6



Flybar for VIOX206 flown or stack mounting. Only with SB-2X6

SB-2X6



Brackets for VIOX206 speakers transport and flown or stack mounting



VIO X205



400 W RMS ACTIVE 2-WAY SPEAKER

LF 2x 5" (1" V.C.), HF 1x 1" (1.4" V.C.)

AVAILABLE WITH 60° x 60° OR 100° x 100° COVERAGE

MAXIMUM VERSATILITY IN TOUR-GRADE APPLICATIONS OR FIXED INSTALLATIONS

MOST COMPACT RDNET CONTROLLED CABINET

Speaker Type	2 Way Active Loudspeaker
Usable bandwidth [-10dB]	75 - 21.000 Hz
Frequency Response [-6dB]	80 - 20.000 Hz
Max SPL	126 dB
HF	1x 1"
Voice Coil HF	1.4"
LF	2x 5"
Voice Coil LF	1"
VIO X205-60 Directivity	60° x 60°
VIO X205-100 Directivity	100° x 100°
Amplifier	400 W RMS Class-D Digipro® G3
Cooling	Convection
Power Supply	Auto-range SMPS
Controller	DSP 28/56 bit
AD/DA Converter	24 bit/48 kHz
Limiter	Peak, RMS, Thermal
Processing	FIR Linear Phase Filters
Signal Input	1x XLR balanced, 1x RJ45 Link (RDNet) 1x USB Data Service
Signal Output	1x XLR balanced, 1x RJ45 Link (RDNet)
Power Socket	1x PowerCON TRUE1 In 1x PowerCON TRUE1 Out
Controls	1x Rotary Encoder (8x EQ presets) 1x Input Attenuation Rotary Switch 1x On-LED 1x Status-LED 1x Signal-LED 1x Limiter-LED
Housing	Wooden Cabinet, Polyurea painting
Wedge Angle	Monitor use 5°
Rigging points	2x M10 Threaded Nut (on top and bottom)
Width x Height x Depth	150 x 485 x 240 mm (5.9 x 19 x 9.4 in)
Weight	7.8 kg (17.2 lbs)

VIO X205

A revolution in VIO X family: newly born VIO X205 condenses the powerful and detailed sound of the ultimate dBTechnologies point source series into a small, ultra-performing cabinet.

Being the most compact system allowing complete remote control via RDNet, VIO X205 acts as the most precise and versatile unit in any tour-grade application as well as in fixed installations. In fact, VIO X205 is available in 2 models, providing a 60°x60° or 100°x100° dispersion pattern.

60° x 60°



100° x 100°



Advanced sound processing featuring Linear Phase FIR Filters allows VIO X205 to deliver an extremely coherent audio performance, standing out for its intelligibility and clarity from every listening position. On-board presets let users adapt High Pass Filters to the chosen application.

Just like other cabinets in the VIO X family, 205 is enabled for real time monitoring and remote control via RDNet protocol and Aurora Net software (Windows and Mac). The cabinet is also provided with on-board controls to set High Pass Filters as well as Input sensitivity.

This solid wooden cabinet is reinforced with a polyurea finish and features M10 threaded nuts on top and bottom allowing installation with accessories WB-VIOX205H (horizontal bracket) or WB-VIOX205V (vertical bracket). The cabinet can be easily installed on pole thanks to SA-VIOX205 pole mount adaptor (35mm) allowing 2 tilt options. Functional cover FC-VIOX205 is also available as an accessory.



VIO X205 is a 2-way speaker equipped with 2x5" (1" voice coil) and 1x1" driver (1.4" voice coil). The 400 W RMS DigiproG3 amplifier powers a cabinet able to deliver up to 126 dB despite its very compact dimensions: only 150 x 485 x 240 mm (WxHxD).

Keeping in mind the needs of the most demanding professionals, VIO X205 is available in 2 models featuring 2 different constant directivity horns allowing a 60° x 60° (for VIO X205-60) or 100° x 100° (for VIO X205-100) dispersion pattern. This means that each user will be able to choose the model that best fits his project as full-range PA, fixed installation, FOH monitoring, front-fill in large sound reinforcement systems, etc.

ACCESSORIES

SA-VIOX205

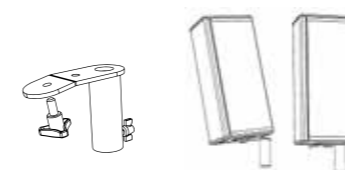

Speaker stand adapter for VIO X205.

WB-VIOX205H

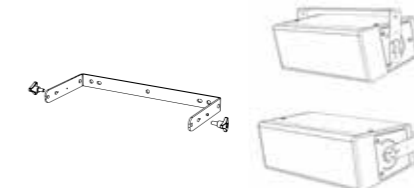

Horizontal wall bracket for VIO X205.

WB-VIOX205V

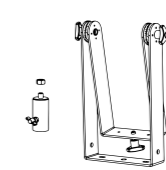

Vertical bracket for VIO X205. 36mm pole mount included.

FC-VIOX205



Functional cover for VIO X205.

WEDGES

The VIO family would not be complete without a focused assortment of professional stage monitors. dBTechnologies presents VIO W, a selection of monitors that share the best of VIO technology, an original acoustic design, and special attention to cabinet design and aesthetic effect on stage. Each model in the VIO W series has been tailored to different production needs, from touring to system integration.



VIO W15T



ACTIVE 2-WAY COAXIAL STAGE MONITOR

NEODYMIUM TRANSDUCERS

1600W RMS CLASS-D AMPLIFIER

ROTATABLE HORN

ADVANCED DSP FEATURING LINEAR PHASE
FIR FILTERS

FULL RANGE SMPS WITH PFC

MODULAR SLOT FOR NETWORK AND
DIGITAL AUDIO EXPANSION CARDS - RDNET
CARD INSTALLED

NFC™ + FRONT LED IDENTIFICATION SYSTEM

SYSTEM TEST FOR QUICK TRANSDUCERS
DIAGNOSTICS

EXCLUSIVE FRONT-REAR GRILLE DESIGN

COAXIAL STAGE MONITOR

With VIO W15T, the perfect touring wedge goes VIO. A powerful yet multiskilled stage monitor, able to keep up with VIO premium line array series on the most challenging live music stages. Making the most of its coaxial acoustic design, along with tour-grade amp technology and electronics, VIO W15T is the perfect stage companion for the most demanding musicians, while allowing for complete networkability and remote control in real-time.

Speaker Type	2-Way Coaxial Active Stage Monitor
Usable Bandwidth [-10dB]	49 - 17,000 Hz
Frequency Response [-6dB]	55 - 16,000 Hz
Max SPL	137.5 dB
HF	1x 1.3", 3" v.c. - Coaxial Neodymium
LF	1 x 15", 3" v.c. - Coaxial Neodymium
Directivity [HxV]	80° x 60°
Amplifier	1600 W RMS Class-D Digipro® G4
Cooling	Convection, Internal fan
Power Supply	Full-range SMPS with PFC (100V--240V~, 50-60Hz)
Controller	DSP 32 bit
AD/DA Converter	24 bit/96 kHz
Limiter	Dual Active Multiband Peak, RMS, Thermal
Processing (filters)	FIR Linear phase
Signal Input	1x XLR female, balanced 1x USB Data Service
Signal Output	1x XLR male, balanced
Power Socket	1x PowerCON TRUE1 In 1x PowerCON TRUE1 Out
Expansion card	RDNET Card (1x RJ45 IN 1x RJ45 Link) Dante Card [Optional]
Controls	1x Switch Flat/Service User 1x System Test Button 1x On-LED 1x Status-LED 1x Signal-LED 1x Limiter-LED
Special Features	NFC™ and Frontal LED Identification System 380V Resistant SMPS IPOS Intelligent Power-On Sequence Opto-isolated floating pre-amp System Test (transducers diagnostics)
Housing	Wooden Cabinet, Polyurea painting
Handles	1 (+ 2 recessions x side)
Rigging Points	2x M10 with rigging points
Width x Height x Depth	650 x 360 x 490 mm (25.59 x 14.17 x 19.29 in)
Weight	29 kg (63.9 lbs)

PERFECT TOURING COMPANION

VIO W15T

VIO W15T is a self-powered box, equipped with a top-notch class D Digipro G4 amplifier, delivering 1600 Watts RMS. Its powerful DSP takes advantage of FIR filters, allowing for very flat frequency and phase response, together with great feedback rejection, and impressive SPL capability up to 137 dB.

VIO amp technology comes with several benefits. First of all, the Power Factor Corrector granting the utmost reliability, regardless of the input voltage. A 380 Volt resistant power supply makes the wedge shock-resistant. Plus, a real-time impedance control allows for a check of transducers' health via Aurora Net software or via the onboard System Test button.



VIO W15T is equipped with a coaxial component encompassing a 15" neodymium woofer and a 3" neodymium driver. HF reproduction is routed through a horn allowing for a sharp 80x60° dispersion pattern.

Users can easily rotate the horn, which reverses the dispersion angle and adapts the wedge to different applications.

The minimal surrounding grille design makes VIO W15T look great on stage. The preamp module is flush-mounted on the side panel so that no connectors are visible. Furthermore, the preamp position allows for side-stacking of two wedges with no gap, while leaving enough room for cables.

A dedicated multifunctional bracket allows for different uses when needed, enabling the wedge for pole, truss, and wall mounting applications.



The wedge is enabled for complete networkability thanks to the RDNNet expansion card (installed by default), allowing users to remotely manage any DSP control such as delay, Eq, and levels via Aurora Net software.

A high-brightness LED bulb behind the grill helps users to recognize, identify, and match each cabinet with its software alias. A dedicated button onboard switches from the factory preset to any Eq previously stored with Aurora Net, with no need to hook it up with the software again.

Just like other VIO systems, the wedge is ready for upgrades with a Dante card.

ACCESSORIES

WB-VIOW15T



Bracket for VIO W15T, wall or pole mounted.

CABLES

CAT6-CAT6-100	CAT6-CAT6 link cable (100cm) for DANTE™ AoIP and RDNNet. EtherCON connectors.
CAT6-CAT6-170	CAT6-CAT6 link cable (170cm) for DANTE™ AoIP and RDNNet. EtherCON connectors.
CAT6-CAT6-500	CAT6-CAT6 link cable (500cm) for DANTE™ AoIP and RDNNet. EtherCON connectors.
DPTC-100L	PowerCON TRUE1-PowerCON TRUE1 power link cable (100cm).
DPTC-120L	PowerCON TRUE1-PowerCON TRUE1 power link cable (120cm).
DPTC-160L	PowerCON TRUE1-PowerCON TRUE1 power link cable (160cm).
DPTC-500L	PowerCON TRUE1-PowerCON TRUE1 power link cable (500cm).
DPTC-1000M	Mains PowerCON TRUE1 cable (10m). Different plugs available for several countries.
DPTC-2000M	Mains PowerCON TRUE1 cable (20m). 16A CekON.

VIO W12T



ACTIVE 2-WAY COAXIAL STAGE MONITOR

NEODYMIUM TRANSDUCERS

1600W RMS CLASS-D AMPLIFIER

ROTATABLE HORN

ADVANCED DSP FEATURING LINEAR PHASE
FIR FILTERS

FULL RANGE SMPS WITH PFC

MODULAR SLOT FOR NETWORK AND
DIGITAL AUDIO EXPANSION CARDS - RDNET
CARD INSTALLED

NFC™ + FRONT LED IDENTIFICATION SYSTEM

SYSTEM TEST FOR QUICK TRANSDUCERS
DIAGNOSTICS

EXCLUSIVE FRONT-REAR GRILLE DESIGN

COAXIAL STAGE MONITOR

Speaker Type	2-Way Coaxial Active Stage Monitor
Usable Bandwidth [-10dB]	56 - 20,000 Hz
Frequency Response [-6dB]	60 - 16,700 Hz
Max SPL	138 dB AES75*
HF	1x 1.3" - 3" v.c. Neodymium
LF	1x 12" - 3" v.c. Neodymium
Directivity [HxV]	60° x 40° rotatable
Amplifier	1600 W RMS Class-D Digipro® G4
Cooling	Convection, Internal fan
Power Supply	Full-range SMPS with PFC (100V--240V-, 50-60Hz)
Controller	DSP 32 bit
AD/DA Converter	24 bit/96 kHz
Limiter	Dual Active Multiband Peak, RMS, Thermal
Processing (filters)	FIR Linear phase
Signal Input	1x XLR female, balanced 1x USB Data Service
Signal Output	1x XLR male, balanced
Power Socket	1x PowerCON TRUE1 In 1x PowerCON TRUE1 Out
Expansion card	RNet Card (1x RJ45 IN 1x RJ45 Link) Dante Card [Optional]
Controls	1x Switch Flat/Service User 1x System Test Button 1x On-LED 1x Status-LED 1x Signal-LED 1x Limiter-LED
Special Features	NFC™ and Frontal LED Identification System 380V Resistant SMPS IPOS Intelligent Power-On Sequence Opto-isolated floating pre-amp System Test (transducers diagnostics)
Housing	Wooden Cabinet, Polyurea painting
Handles	1 (+ 2 recessions x side)
Rigging Points	2x M10 with rigging points
Width x Height x Depth	550 x 360 x 490 mm (21.65 x 14.17 x 19.29 in)
Weight	22.5 kg (49 lbs)

PERFECT TOURING COMPANION

VIO W12T

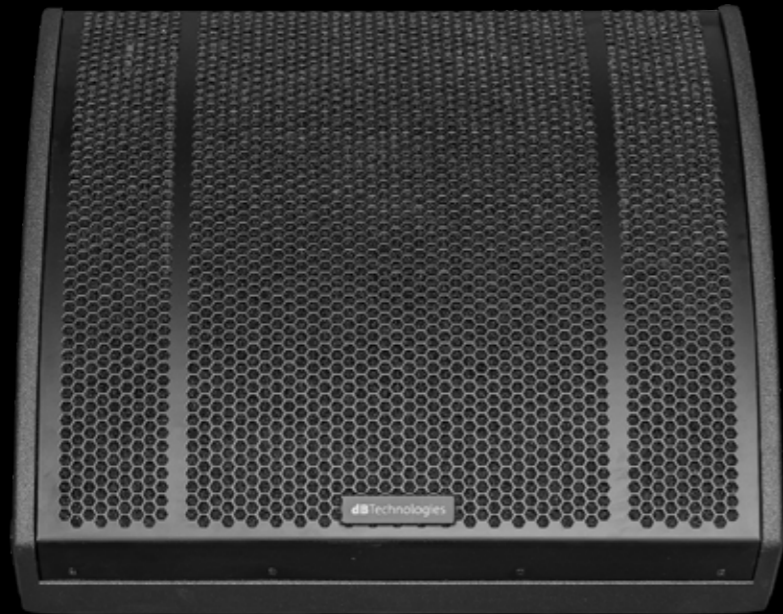

The VIO W12T from dBTechnologies is a high-performance 12" coaxial stage monitor designed to meet the demands of touring professionals, live venues, and production companies. With its coaxial transducer architecture and rotatable horn, the monitor delivers precise 60° x 40° coverage and a tightly focused sound field—ideal for all applications including vocals, instruments, and speech reinforcement on stage.

Engineered for power and clarity, the system achieves a maximum SPL of 138 dB (AES75), placing it among the most capable wedges in its class.

This active, two-way design is driven by a 1600W RMS Class-D amplifier, while dBTechnologies' proprietary Digipro G4 platform with integrated 96kHz DSP ensures linear phase response through FIR filtering, advanced thermal

limiting, and real-time impedance monitoring, delivering maximum performance with consistent tonal integrity and system protection. Remote control and monitoring via on-board RDNet™ and an A2Net™ upgrade enable advanced remote tuning, impedance monitoring, and delay adjustments while Dante™ compatibility (via optional card) further extends its versatility in networked environments.



Encased in a road-ready wooden enclosure with a rugged polyurea-coating, the VIO W12T is built for durability. With a practical form factor, weighing just 22.5 kg (49 lbs), and integrated rigging points, it's equally suited for rental fleets deployed on demanding touring stages and festivals, as well as fills and fixed installations in houses of worship and theatres.



ACCESSORIES

SA-WT



Stand Adapter for VIO W

ACCESSORIES

WB-VIOW12T



Bracket for VIO W12T, wall or pole mounted.

CABLES

CAT6-CAT6-100	CAT6-CAT6 link cable (100cm) for DANTE™ AoIP and RDNet. EtherCON connectors.
CAT6-CAT6-170	CAT6-CAT6 link cable (170cm) for DANTE™ AoIP and RDNet. EtherCON connectors.
CAT6-CAT6-500	CAT6-CAT6 link cable (500cm) for DANTE™ AoIP and RDNet. EtherCON connectors.
DPTC-100L	PowerCON TRUE1-PowerCON TRUE1 power link cable (100cm).
DPTC-120L	PowerCON TRUE1-PowerCON TRUE1 power link cable (120cm).
DPTC-160L	PowerCON TRUE1-PowerCON TRUE1 power link cable (160cm).
DPTC-500L	PowerCON TRUE1-PowerCON TRUE1 power link cable (500cm).
DPTC-1000M	Mains PowerCON TRUE1 cable (10m). Different plugs available for several countries.
DPTC-2000M	Mains PowerCON TRUE1 cable (20m). 16A CekON.

VIO W10

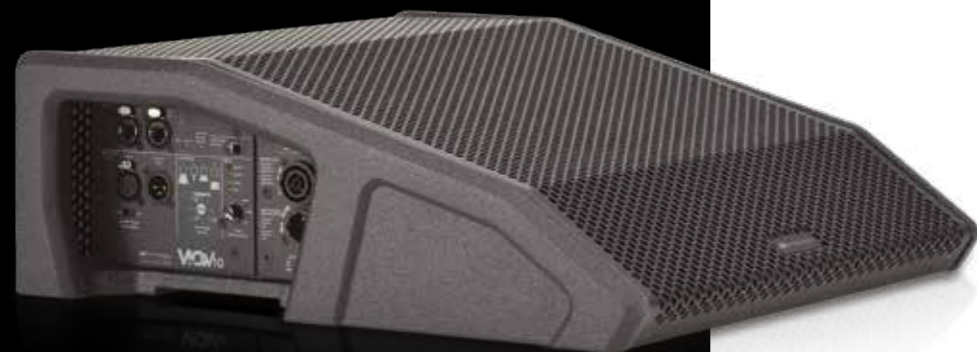

VIO W10 is an ultra-slim wedge speaker designed to be discreetly integrated in broadcast studios, theatre stages, congress facilities and wherever an unobtrusive and versatile wedge is needed.

The 2-way system is equipped with 4x 4" neodymium HF speakers and 1x 10" woofer, placed in an exclusive anti-feedback acoustic configuration. The cabinet is driven by a 400 W RMS Digipro G3 amplifier and full remote control is enabled via RNet and Aurora Net software.

VIO W10's wooden cabinet comes with a black polyurea finish and an exclusive front-rear-grille design which contributes to a peculiar yet discreet look, with a special attention to details. In fact, an integrated handle is hidden on left side to ease transport and a special groove carved on bottom side facilitates the passage of cables under the cabinet, allowing a clean and tidy look on stage.

ACTIVE 2-WAY WEDGE MONITOR

INNOVATIVE ULTRA-SLIM DESIGN

HEIGHT 165 MM ONLY

400 W RMS CLASS-D AMPLIFIER

ANTI-FEEDBACK ACOUSTIC CONFIGURATION

VARIABLE ACOUSTIC FOCUS

REMOTE CONTROL VIA RNET

EXCLUSIVE FRONT-REAR GRILLE DESIGN

Speaker Type	2-Way Active Wedge Monitor
Usable Bandwidth [-10dB]	58 - 15,000 Hz
Frequency Response [-6dB]	68 - 14,000 Hz
Max SPL	126 dB
HF	4x 4", 1" v.c. - Neodymium
LF	1x 10", 2.5" v.c.
Directivity	Dependent on Focus Preset
Amplifier	400 W RMS Class-D Digipro® G3
Cooling	Passive Convection
Power Supply	Auto-range SMPS
Controller	DSP 28/56 bit
AD/DA Converter	24 bit/48 kHz
Limiters	Peak, RMS, Thermal
Processing (filters)	FIR Linear phase
Signal Input	1x XLR female, 1 x RJ45 Link (RNet) 1x USB Data Service
Signal Output	1x XLR male, 1 x RJ45 Link (RNet)
Power Socket	1x PowerCON TRUE1 In 1x PowerCON TRUE1 Out
Controls	1x Rotary Encoder (8 presets) 1x Input Sensitivity Encoder 1x Mic / line switch 1x On-LED 1x Status-LED 1x Signal-LED 1x Limiter-LED
Housing	Wooden Cabinet, Polyurea painting
Handles	1 on left side
Width x Height x Depth	450 x 165 x 480 mm (17.71 x 6.49 x 18.89 in)
Weight	13.7 kg (302 lbs)



FOCUS PRESET

Digital Sound Processing allows a variable acoustic focus via on-board presets or via software. As a matter of fact, user can easily adapt the wedge performance to the application, choosing among 4 different options: default, close narrow, close wide, far.

TECHNOLOGIES

SYSTEM TEST



A built-in measurement system can read the transducers impedance in real time and provide an instant feedback on the health of your system. This controls is performed constantly or it can be forced by the user at any time, remotely or from the amplifier panel.

SMPS WITH PFC



The Power Factor Corrector greatly improves the efficiency of the system. Performances of the amplifier are very stable and consistent, regardless of the quality of the mains. This also grants a worldwide compatibility of the power supply - from 90V to 265V 50/60Hz - and limits power consumption.

380V RESISTANT SMPS



The final amplifiers will be switched off in case of an undesired strike of 380V current, saving them from any damage. The auxiliary power supply - 380V tolerant - determines a safe range of operability for the main power supply.

IPOS



The Intelligent Power-On sequence circuit controls the sequence in which the main power supplies of all units within an array ramp up. As a result, each module is switched on in a different time frame, keeping the overall system's inrush current low.

NFC AND LED



Near Field Communication proximity sensors are used to determine the position of each box within an array. This technology, together with a hi-brightness LED bulb on the front of the enclosure, contributes to help the user to recognize and match each box with their position on the remote control software.

IR POSITIONING



A system of infrared ports enables a single speaker to recognize companion cabinets placed on top and/or sides, and, subsequently, size and configuration of the cluster, allowing for a consistent DSP processing throughout the whole cluster. When needed, the system automatically mirrors parameters set on a single cabinet on the whole cluster.

OPTO-ISOLATED PREAMP

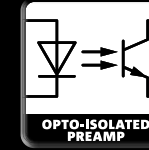

The floating audio input design grants a digital optical isolation between earth ground from the mains and the audio ground flowing into the Preamp board. This galvanic isolation greatly improves resistance to interferences and any unwanted buzzing and noises.

EXPANSION CARD SLOT

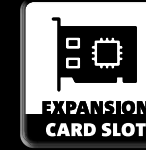

The preamplifier comes with a RDNet card installed. The user will be able to upgrade the system by replacing the RDNet card with an Audinate® Dante® card for audio over Ethernet and remote control on a single cable solution - sold separately.

USB DATA PORT

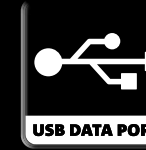

Thanks to this universal data port, the user will be able to perform firmware upgrades.

INCLINOMETER



Inside every array of VIO series, you can find a sensor that allows you to check immediately the absolute inclination in degrees of flown speaker through Aurora Net software. This turns out to be very useful when you need to verify the correct installation of flown speakers.

LINEAR PHASE FIR FILTERS



A low-latency sound processing featuring Linear Phase FIR filters allows VIO cabinets to deliver an extremely coherent audio performance, standing out for its intelligibility and clarity from every listening position. This is also achieved by making the phase response as linear as possible, avoiding any distortion.

LINE ARRAY MODULES



Speaker Type	2-Way Active Line Array Module	3-Way Active Line Array Module	2-Way Active Line Array Module	3-Way Active Line Array Module	3-Way Active Line Array Module	Active Bassreflex Subwoofer	Active Bassreflex Subwoofer	Active Horn-Loaded Flyable Subwoofer	Active Bassreflex, Semi-horn Loaded Sub	Active Bassreflex Subwoofer	Flyable Active Bassreflex subwoofer	Speaker Type
Usable Bandwidth [-6dB]	75 - 18,000 Hz [FW 1.x] 75 - 20,000 Hz [FW 2.x]	75 - 18,000 Hz	67 - 18,000 Hz [FW 1.x] 62 - 20,000 Hz [FW 2.x]	60 - 17,000 Hz	55 - 18,600 Hz	40 Hz - (user frequency LPF)	55 Hz - Xover dependent [FW 1.x] 53 Hz - Xover dependent [FW 2.x]	39 Hz - Xover dependent [FW 1.x] 36 Hz - Xover dependent [FW 2.x]	39 Hz - Xover dependent [FW 1.x] 36 Hz - Xover dependent [FW 2.x]	28 Hz - Xover dependent	28 Hz - Xover dependent	Usable Bandwidth [-6dB]
Max SPL	One Unit: 133.5 dB	One Unit: 138.5 dB AES75	One Unit: 135 dB	One Unit: 141 dB	One Unit: 142 dB	134 dB	139 dB	139 dB	143 dB	143 dB	143 dB	Max SPL
HF	1x 1.4', 3' v.c. - Neo	1x 1.4' exit, 3'-2' v.c. Coaxial, Neo	1x 1.4', 3' v.c. - Neo	1x 1.4', 4' - 2.5' v.c. - Coaxial Neo	4x 6.5', 2' v.c. - Neo							HF
MF												MF
LF	2x 8', 2' v.c. - Neo	2x 8', 2.5' v.c. - Neo	2x 10', 2.5' v.c. - Neo	2x 10', 2.5' v.c. - Neo	2x 12', 3' v.c. - Neo	1x 15', 4' v.c. Neodymium	1x 18', 4' v.c.	1x 18', 4' v.c.	3x 18', 4' v.c.	2x 18', 4' v.c.	2x 18', 4' v.c.	LF
Directivity	100° (horizontal)	110° (horizontal)	100° (horizontal)	100° (horizontal)	90° (horizontal)	Omnidirectional	Omnidirectional	Omnidirectional	Omnidirectional	Omnidirectional	Omnidirectional	Directivity
Amplifier	900 W RMS Digipro® G3	1600 W RMS Class-D	900 W RMS Digipro® G3	1600 W RMS Digipro® G4	3200 W RMS [2x 1600 W RMS Digipro® G4]	900 W RMS Digipro® G3	1600 W RMS Digipro® G4	1600 W RMS Digipro® G4	2700 W RMS Digipro® G3	3200 W RMS [2x 1600 W RMS Digipro® G4]		Amplifier
Width x Height x Depth	600 x 260 x 390 mm 25.98 x 10.23 x 15.35 in	600 x 260 x 390 mm 25.98 x 10.23 x 15.35 in	720 x 320 x 520 mm 28.35 x 12.6 x 20.47 in	720 x 320 x 520 mm 28.35 x 12.6 x 20.47 in	1100 x 380 x 450 mm 43.31 x 14.96 x 17.72 in	650 x 420 x 550 mm 25.6 x 16.5 x 21.7 in	720 x 530 x 700 mm 28.34 x 20.47 x 27.56 in	720 x 520 x 700 mm 28.34 x 20.47 x 27.56 in	1300 x 520 x 800 mm 51.18 x 20.47 x 31.5 in	1300 x 520 x 800 mm 51.18 x 20.47 x 31.5 in	1300 x 520 x 800 mm 51.18 x 20.47 x 31.5 in	Width x Height x Depth
Weight	18.1 kg - 39.9 lbs	22 kg - 48.5 lbs	28.6 kg - 63 lbs	31.3 kg - 69 lbs	54.4 kg - 119.93 lbs	32.8 kg - 72.3 lbs	47 kg - 103.62 lbs	45.1 kg - 99.42 lbs	103.9 kg - 229.06 lbs	85.6 kg - 188.72 lbs	100 kg - 220 lbs	Weight

SUBWOOFERS

ACTIVE LINE-SOURCE SPEAKERS



Speaker Type	2 Way Active Cluster Speakers			3 Way Active Loudspeaker			2 Way Active Loudspeaker				2-Way Active Wedge		2-Way Coaxial Active Stage Monitor	2-Way Coaxial Active Stage Monitor	Speaker Type
Usable Bandwidth [-6dB]	55 - 18,000 Hz	46 - 18,000 Hz	51 - 18,000 Hz	57 - 19,200 Hz	37 - 18,000 Hz	82 - 20,000 Hz [FW 1.x] 70 - 21,400 Hz [FW 2.x]	79 - 21,000 Hz [FW 1.x] 65 - 21,000 Hz [FW 2.x]	72 - 21,000 Hz [FW 1.x] 60 - 21,000 Hz [FW 2.x]	80 - 20,000 Hz	70 - 18,000 / 70 - 17,500	68 - 14,000 Hz	60 - 16,700	55 - 16,000	Usable Bandwidth [-6dB]	
Max SPL	139 dB	140 dB	141 dB	138 dB	137 dB	130 dB	132 dB	133.5 dB	126 dB	131 dB	126 dB	138 dB AES75	137.5 dB	Max SPL	
HF	1x 1.4', 3' v.c. Neo	1x 1.4', 3' v.c. Neo	1x 1.4', 3' v.c. Neo	1x 1.4', 4' - 2.5' v.c. - Coaxial Neodymium	90' x 50' - 5' tilted down	1x 1.4', 2.5' v.c. - Neo	1x 1.4', 2.5' v.c. - Neo	1x 1.4', 2.5' v.c. - Neo	1x 1.4', 2.5' v.c. - Neo	1x 1.4', 2.5' v.c. - Neo	1x 1.4', 2.5' v.c. - Neo	1x 1.3', 3' v.c. - Neo	1x 1.3', 3' v.c. - Neo	HF	
MF														MF	
LF	1x 12', 3.5' v.c. Neo	1x 15', 3.5' v.c. Neo	2x 12', 3' v.c. Neo	2x 10', 2.5' v.c. Neo	1x 15', 4' v.c. Neo	1x 10', 2.5' v.c. - Neo	1x 12', 3' v.c. - Neo	1x 15', 3' v.c. - Neo	1x 15', 3' v.c. - Neo	2x 5', 1' v.c.	2x 6.5', 1.75' v.c.	1 x 10', 2.5' v.c.	1x 12' - 3' v.c. Neo	LF	
Directivity [HxV]	22.5' x 55' (+20°/-35')	22.5' x 45' (+15°/-30')	22.5' x 55' (+20°/-35')	90' x 40'	90' x 50' - 5' tilted down	90' x 40'	60' x 40'	60' x 40'	60' x 40'	60' x 60' / 100' x 100'	60' x 90' / 15' x 100'	Dependent on Focus Preset	60' x 40' rotatable horn	Directivity [HxV]	
Amplifier	1600 W RMS Digipro® G4	1600 W RMS Digipro® G4	1600 W RMS Digipro® G4	1400 W RMS Class-D Digipro® G4	900 W RMS Digipro® G3	400 W RMS Digipro® G3	900 W RMS Digipro® G3	900 W RMS Digipro® G3	900 W RMS Digipro® G3	400 W RMS Digipro® G3	400 W RMS Digipro® G3	400 W RMS Digipro® G3	1600 W RMS Digipro® G4	Amplifier	
Width x Height x Depth	379 x 787 x 495 mm 14.92 x 30.98 x 19.48 in	436 x 892 x 630 mm 17.16 x 35.11 x 24.80 in	379 x 1132 x 495 mm 14.92 x 44.56 x 19.48 in	300 x 780 x 430 mm 11.8 x 30.7 x 16.9 in	420 x 820 x 520 mm 16.5 x 32.3 x 20.5 in	280 x 580 x 375 mm 11.02 x 21.65 x 14.76 in	340 x 650 x 445 mm 13.38 x 25.5 x 17.51 in	400 x 750 x 475 mm 15.74 x 29.52 x 18.7 in	150 x 485 x 240 mm 5.9 x 19.1 x 9.4 in	210 x 650 x 270 mm 8.3 x 25.6 x 10.6 in	450 x 165 x 480 mm 17.71 x 6.49 x 18.89 in	550 x 360 x 490 mm 21.65 x 14.17 x 19.29 in	650 x 360 x 490 mm 25.98 x 14.17 x 19.29 in	Width x Height x Depth	
Weight	31.8 kg - 70.1 lbs	40.6 kg - 89.5 lbs	41.7 kg - 91.9 lbs	28 kg - 61.5 lbs	39.5 kg - 87.1 lbs	16.6 kg - 36.59 lbs	20.7 kg - 45.63 lbs	25.4 kg - 55.99 lbs	7.8 kg - 17.2 lbs	17.3 kg - 38.14 lbs	13.7 kg - 30.2 lbs	22.5 kg - 49 lbs	29 kg - 65.9 lbs	Weight	

PBS-63EU

- 63A CEKON POWER INPUT WITH 5 M CABLE INCLUDED
- 4x LKS 19 MULTIPIN OUTPUTS - 24x POWERCON TRUE
- 1x 32A CEKON LINK OUTPUT
- 6x POWERCON TRUE AUXILIARY OUTPUTS
- 1x 16A CEKON AUXILIARY OUTPUT
- BUILT-IN DIGITAL AC MULTIMETER
- TOUR GRADE LKS19 MULTI-PIN CONNECTORS
- ROAD READY FLIGHT CASE



dBTechnologies PBS-63EU represents the most professional solution to provide power distribution for mid to large dBTechnologies sound reinforcement systems, including flown arrays, ground-stacked sub arrays, fills and stage monitoring. This power rack has been designed to meet the highest standards in reliability and performance, in order to serve as an excellent tool for touring applications. From a single 63-Ampere three-phase Cekon connector (5meters cable included), PBS-63EU distributes the power in 4x LKS19 multipin outputs (IP 67 rated), 1x 32A Cekon service link for chain motor controls or aux output, 1x 16A Service output and 6x PowerconTrue link outputs. All outputs are equipped with individual RCBOs (Residual Current-operated Circuit-Breaker with Overcurrent protection) so in case of damage, only the faulty output is missed while the rest of the system continues to function seamlessly.

CABLES

- LKS19-1000L** LKS19 Socapex Link Cable (10m).
- LKS19-2000L** LKS19 Socapex Link Cable (20m).
- LKS19-6PT** LKS19 Cable to 6x PowerCONTrue FanOUT Cable.

AC26N, audio digital processor, has been designed for fixed and touring installations, and allows you to control any professional audio system, both active and passive. Equipped with two inputs and six outputs balanced analogically, two in/out digital AES/EBU and an RDNet control, this processor allows a perfect control in a simple and complete way. Each output possesses a parametric equalizer, delay, phase and level control, completely run by a powerful 28/56 Bit DSP, unique in its kind. This processor control may be directed by the front control panel or through an RDNet connected computer.

CABLES

- RJ45-RJ45-75** RJ45-RJ45 link cable (75cm) for RDNet-equipped devices.
- RJ45-RJ45-150** RJ45-RJ45 link cable (150cm) for RDNet-equipped devices.
- RDC-45F** RJ45 to XLR 3 poles female conversion cable (6 cm).
- RDC-45M** RJ45 to XLR 3 poles male conversion cable (6 cm).



SOFTWARE



- REAL TIME MONITORING & CONTROL OF ALL VIO SYSTEMS
- ADVANCED SELF-TAILORED DSP MANAGEMENT
- INTUITIVE DESIGN & USER INTERFACE
- CROSS PLATFORM WIN AND MAC OSX
- WORKS VIA ETHERNET OR USB
- SMART AUTO-GROUPING FUNCTIONS

- TOUCH ORIENTED MANAGEMENT ON PORTABLE DEVICES
- ZOOM-IN / ZOOM OUT FEATURE (WYSIWYG)
- MATCHING FUNCTION
- SUBWOOFER DELAY MANAGEMENT
- SELECTABLE HIGH-CONTRAST DAYLIGHT SKIN

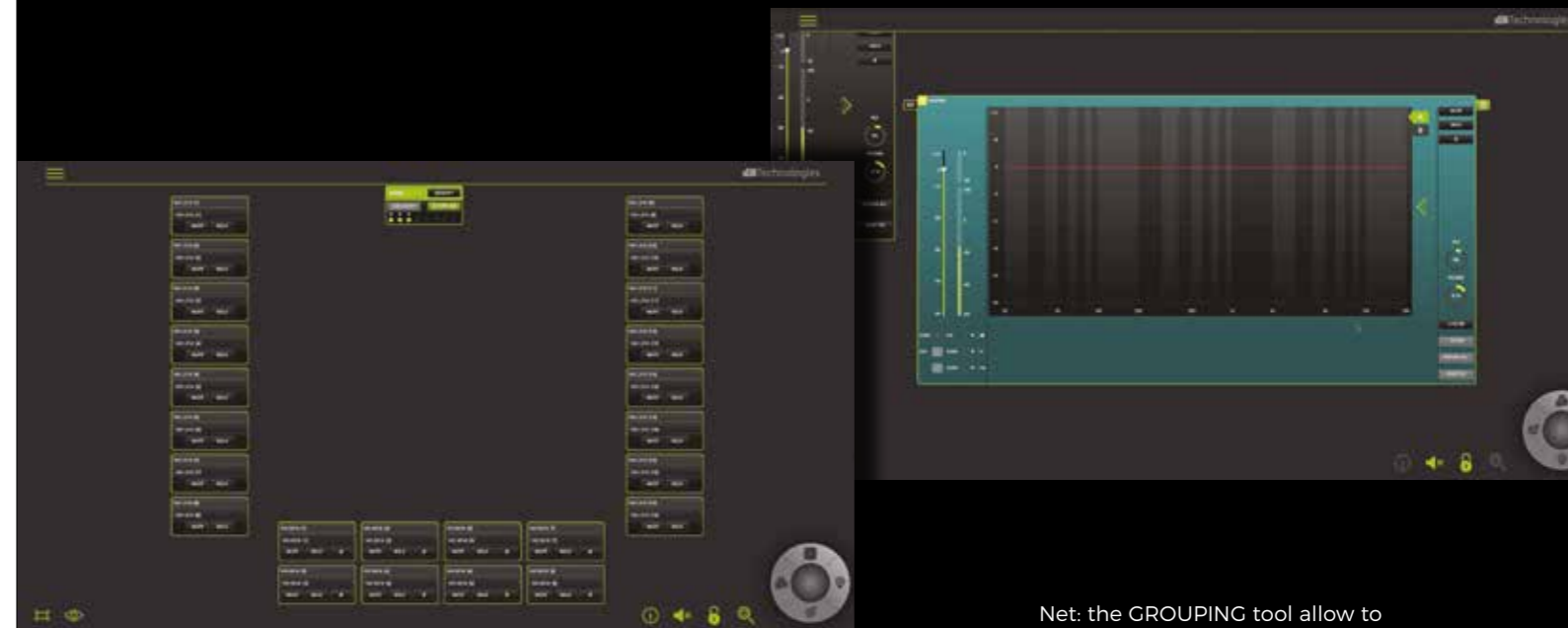

Aurora Net is the software developed by dBTechnologies allowing remote monitoring and real-time control of all systems in VIO series and every other dBTechnologies audio system equipped with an RDNet card.

Cross-platform developed (Win, Mac OSX) by dBTechnologies Software Department in order to guarantee maximum reliability, Aurora Net works via Ethernet cable (or alternatively via XLR), allowing for an advanced, completely customizable DSP control and DIGITAL Audio management (via Dante™ protocol) on the same cable.

The intuitive layout has been designed for maximum usability and allows for a touch-oriented management on portable devices, and, last but not least, allows a smooth and intuitive workflow. The workspace is designed to show all the main functions at a glance, and allows users to operate through a single-click workflow. Users can check the complete PA system in use at a glance or manage each single element thanks to a fast and detailed zoom-in/zoom out incremental display feature.

Among the main functions of Aurora

Net: the GROUPING tool allow to select groups of items and modify EQ, delay or other controls. The MATCHING function works through an intuitive dialog box and it's a great time-saving tool, especially in touring applications, allowing users to upload a pre-designed show file to match with the configuration set in a specific gig.

The SUBWOOFER DELAY MANAGEMENT enable users to include all subs in the Arc delay management window, where Aurora Net automatically assigns appropriate delays depending on the array size and the target dispersion angle. The integrated graphic user interface can be changed to a high contrast skin, perfectly usable even in broad daylight.

SOFTWARE



dBTechnologies Composer is a line array configuration software which has been especially developed to optimize VIO and DVA systems alignment and acoustic performance. It is possible to simulate system reinforcement physics in order to set up a system in a fast and easy way according to your needs and the safety precautions.

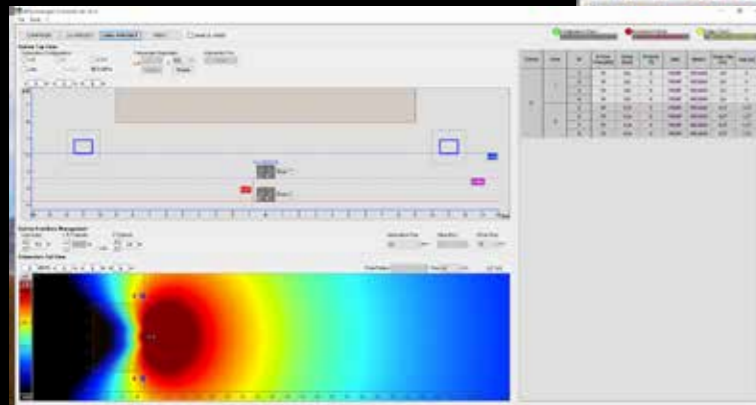
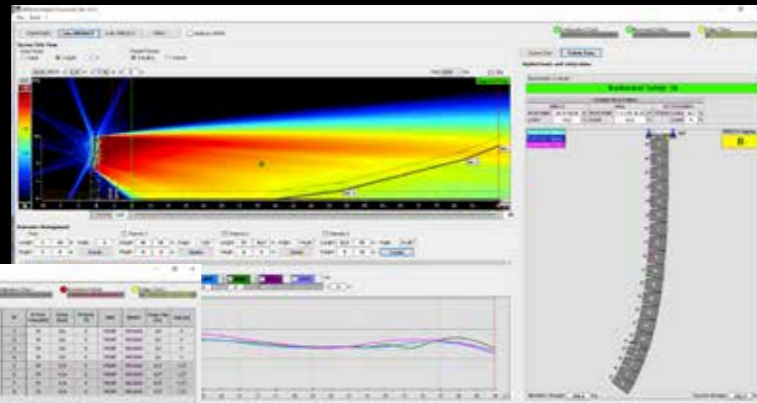

Furthermore the software allows the user to predict acoustic coverage of both tops and subs, splay angles and it automatically checks the set up presets in order to evaluate the efficiency of the system and its nominal coverage.

EASE GLL DATA

All VIO users can easily simulate the acoustical performance of their VIO system in order to find the optimal setup for a given venue. In fact, *.GLL data files for VIO systems are available for free download at dbtechnologies.com.

GLL files are ready for AFMG's EASE and EASE Focus 3 acoustic simulation software, allowing system designers to check mechanical safety of flown line arrays, point sources, and sub arrays, define audience areas, calculate sound coverage and frequency response and much more.

GLL files are available for all VIO Line arrays (VIO L208, L210, L1610 and L212), all VIO subs (VIO S115, S118, S118R, S218, S318), all VIO C units, and all VIO X point source speakers, alongside with many other dbtechnologies products.

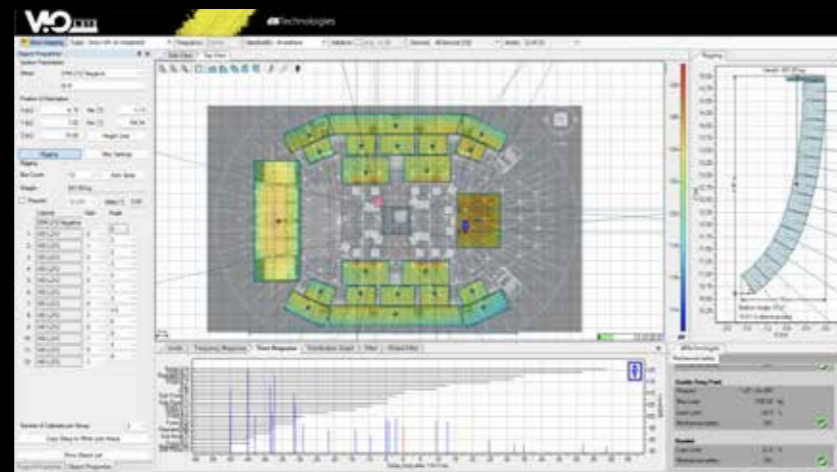

SOFTWARE

VIO FIRMWARE 2.0

UNIFORM PHASE RESPONSE

ALIGNED SENSITIVITY

EQUAL LATENCY

OPTIMIZED FREQUENCY RESPONSE

SEAMLESS MIX-AND-MATCH OF DIFFERENT VIO TOPS, SUBS, AND TOP+SUB

ENHANCED LOW-END EXTENSION FOR VIO SUBS

ON-BOARD DELAY BOOST

COMMON VOICING ACROSS DIFFERENT VIO CABINETS

MASSIVE TIME-SAVING FOR PA ALIGNEMENT AND TUNING

BATCH UPGRADE AVAILABLE VIA AURORA NET 1.1

VIO FIRMWARE 2.0 is the must-have upgrade for all speakers in the VIO series. Since the first VIO releases a few years ago, dBTechnologies engaged in a constant dialogue with the worldwide, ever-growing community of VIO users. This allowed us to collect countless data, case studies, stories from the world of touring and sound integration, as well as invaluable contributions from top sound engineers. This priceless feedback is the foundation for the development of VIO firmware 2.0. Redefining four essential aspects of each VIO cabinet (phase response, latency, frequency response, and sensitivity) Firmware 2.0 aims at increasing acoustic compatibility among all VIO speakers, and dramatically speeds up setup operations of combined VIO systems.

Thanks to firmware 2.0, every VIO cabinet makes the most of its onboard DSP featuring linear phase FIR filters, resulting in a perfectly consistent phase response when assembling various VIO products in one single setup. Moreover, the freshly designed DSP workflow brings all VIO systems' phase responses to the same page. For example, the behavior of all VIO line arrays in the low-mid area has been standardized, to the great advantage of hybrid arrays coherence. Also, firmware 2.0 drives phase response uniformity across all VIO subwoofers, resulting not only in a more consistent performance of combined VIO subwoofer models but also in the smoothest coupling with any VIO top.

Firmware 2.0 standardizes latency across the entire VIO series, regardless of speaker type, acoustic loading or DSP build. This way, users don't need to bother about the inherent latency of a single cabinet, and they will be able to align the PA very quickly, even by simply using a rangefinder to measure the distance between speakers. Thanks to a perfectly identical latency, users also get a coherent sum out of a line-array or point-source speaker stacked on any VIO subwoofer, avoiding any additional processing or verification.

Firmware 2.0 unifies the input sensitivity of every VIO speaker, enabling a precise, predictable, and consistent behavior of the limiters across the entire PA, from little front-fills or delay speakers, up to the main arrays, and it will be very easy for users to keep headroom under control. Plus, FW 2.0 also enables an extended onboard delay capability on some selected VIO systems (equipped with Digipro G4 amp module) up to a whopping 560ms (194m / 637ft). This is extremely useful for delay systems very distant from the main PA.

Since the different VIO systems have come into existence at different moments over a considerable time frame, given the technological advances, and the precious market feedback, it was time for a refreshing of the voicing of some VIO cabinets. Firmware 2.0 operates on the frequency response of single cabinets to get a uniform and distinctive voicing in all VIO family. One of the main focuses of this voicing update concerns the subwoofer series: in fact, Firmware 2.0 extends the low-end response of most subs and optimizes their overall performance, resulting in a tighter, fuller, and more precise sound reproduction.

Each VIO cabinet can be upgraded individually via USB cable or, alternatively, users will be able to update simultaneously all VIO cabinets connected via RNet using the latest Aurora Net release (version 1.1 or later is necessary). The upgrading process is intuitive and safe from any risk: in case of power loss or other failures, the speakers will automatically fold back to the previous release.

N.B. Speakers with Firmware 2.0 are not compatible with the ones installing previous firmware releases. Users must update all older VIO products (firmware 1.x) if they wish to deploy them together with products equipped with Firmware 2.0.

REFERENCES

Sequoie Music Park

Festival, Bologna IT
22/06/2022



EQUIPMENT USED

- 24 VIO L212
- 5 VIO L208
- 16 VIO S218
- 12 VIO S218F
- 4 VIO C212

VIO L212 had the chance to sound the Sequoie Music Park 2022 again to double the dominant and homogeneous acoustical performance that marked the 2021 edition. The configuration for this supreme festival is feature by multiple systems of the touring line, with: 24 VIO L212, 6 VIO S218F flown in per side in cardioid configuration, 14 VIO S218 ground-stacked in cardioid configuration, 5 VIO L208 as front fills, 2 VIO C212 + 1 VIO S218 per side as side fills.

REFERENCES

The New Divas Show in Wien

TV show, Vienna, AU
28/07/2023



EQUIPMENT USED

- 24 VIO L208
- 2 VIO S118
- 2 VIO S218
- 4 VIO X205

PBS's newest TV special "The New Divas" debuted at Wiener Konzerthaus. Five talented international singers delighted as protagonists and interpreters of the complex and multifaceted sentiments and technique of the fourth art; the PA designed by the team consisted of a main ft. VIO L208, a system particularly suitable in settings where detailed and sharp acoustics are strictly required, and the configuration adopted met the inherent and peculiar needs of the show.

Irish Fest 2022

Festival, Milwaukee WI
31/08/2022



EQUIPMENT USED

- 18 VIO L212
- 6 VIO L1610
- 4 VIO L210
- 21 VIO S218
- 1 VIO S118
- 4 VIO W15T

The attendance of the Irish Fest, dedicated to Celtic-Irish culture and tradition, was about 85,000, plus 4500 volunteers and artists from 18 to 21 August at the Maier Festival Park. The Audio Biz team provided the VIO Series premium touring technology to sound the Ciderboys Rock (Summerfest Uline) Stage, which was built to gather a broad audience with 9,551 as Overflow Capacity, 7,300 during the Full Show (including Standing Room), and 6,703 as Seated Capacity.

Jungle Music Festival

Festival, Urumqi, Xinjiang, CH
03/08/2023



EQUIPMENT USED

- 32 VIO L212
- 16 VIO L1610
- 12 VIO L210
- 32 VIO S218
- 5 VIO S118
- 16 VIO W15T

The Jungle Music Festival, jointly produced by Huayi Starlight, Funchy Music, and SJ Entertainment Media, took place in Urumqi, Xinjiang, with nearly 100,000 spectators during two days of vibrant celebration of popular typical music. The PA designed and crafted for the big event consisted of: main: 32 VIO L212, side fill: 16 VIO L1610, Front fill: 12 VIO L210, subs: 32 VIO S218, monitors: 16 VIO W15T, stage side fill: 6 L210s + 4 VIO S118, drum sub: 1 S118.

REFERENCES

Unipol Arena

Indoor installation, Bologna IT
22/04/2021

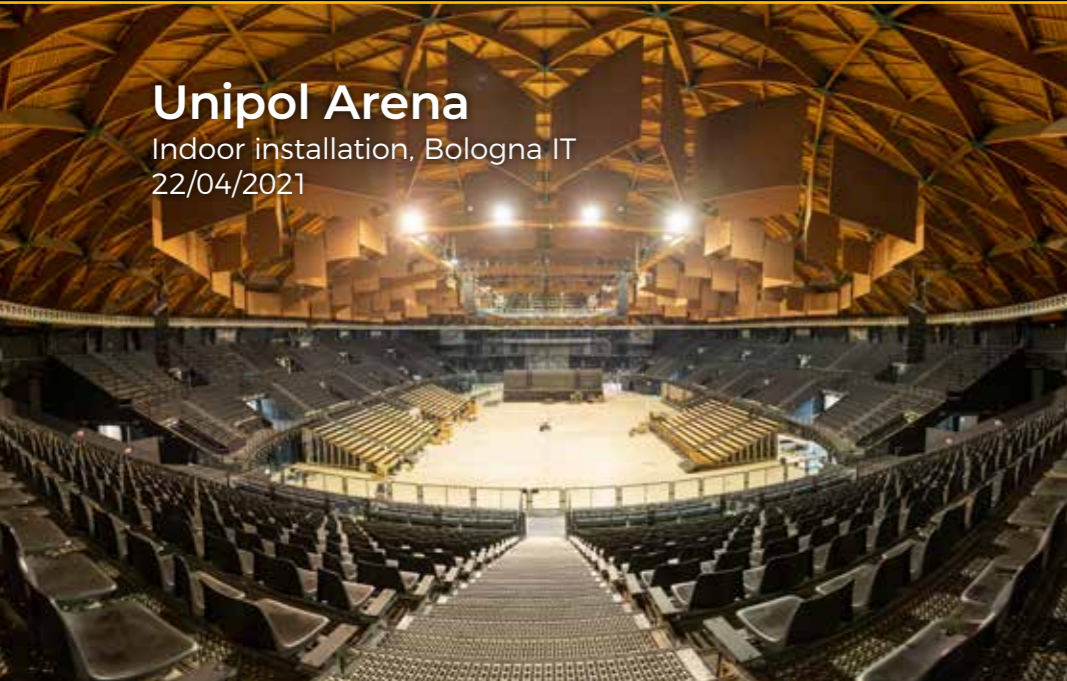

EQUIPMENT USED

- 24 VIO L212
- 61 VIO L210
- 18 VIO S218

VIO Series becomes resident PA for Unipol Arena in Bologna, Italy. For the full-scale line array system VIO L212, this is the most congenial ecosystem to fully exploit the most advanced features of the VIO technology. The project includes a complex and carefully calibrated articulation to cover a large main acoustic area hosting big productions and audiences, to which a conference area is added, powered by the dBTechnologies VIO X brand systems.

REFERENCES

Club Max

Indoor installation, Brixen IT
30/10/2019



EQUIPMENT USED

- 12 VIO L208
- 3 VIO S218
- 2 VIO X12
- 2 VIO S118R
- 4 VIO X10

The VIO Series systems VIO L208, VIO S218 and VIO X technology are now the official audio equipment for Club Max in Brixen (Italy); this disco venue is known as the best disco club in South Tyrol and surroundings. Club max is in fact a real reference point for the night-life and fun and provides musical experiences for any kind of style and taste. The configuration of the acoustic project is designed as follows:
Main (DJ front): 12 VIO L208 (6 per side) + 3 VIO S218, DJ Monitor: 2 VIO X12 + 2 VIO S118R, Side fill: 4 VIO X10

Antytila - Hello Tour 2019

Stadium tour, Ukraine
14/11/2019



EQUIPMENT USED

- 24 VIO L212
- 12 VIO L210
- 18 VIO S218

From the lights and colors of "Hello Tour", the Ukrainian pop-rock band Antytila consecrated itself all over the Country and beyond. In 2019 they released a project which was on the stages of the most important stadiums and venues to celebrate the new album and the 10th anniversary of the band's birth. The PA by PR Music involved the VIO L212 system together with its complement VIO S218 and VIO L210 line array system as side fill; the configuration is designed to ensure an optimal and uniform sound coverage to the wide spaces of each stadium.

Viper Room

Indoor installation, Los Angeles CA
12/03/2020



EQUIPMENT USED

- 6 VIO L208
- 6 DVX DM12TH
- 2 SUB 15H
- 6 DVX DM12TH
- 2 IG1T

VIO L208 enters The Viper Room in Los Angeles and conquers the permanent installation. It was chosen as PA for the sound of this important club as a highly appreciated sound reinforcement solution for small indoor venues thanks to its logistics and mechanics features and the detailed acoustic performances; the configuration in use also includes DVX and INGENIA systems by dBTechnologies: Main: 6 VIO L208 (3 per side), Monitors: 6 DVX DM 12 TH and 1 SUB 15H as drum fill, Downstairs Viper Room: 2x IG1T and 1x SUB 15H.

REFERENCES

Caparezza - Prisoner 709 Tour

Multiple outdoor venues, Italy
01/07/2018 - 31/08/2018



EQUIPMENT USED

- 32 VIO L212
- 8 VIO L210
- 24 VIO S218

VIO L212 was the main PA for the outdoor tour of Italian rap artist Caparezza. The configuration has been adapted to the dimensions and characteristics of the different venues. Normally it was 16 tops per side with 24 subs and 8 VIO L210 used as frontfill. VIO S218 subs were configured as arc in stacks of 3 subs each, with the central cabinet in reverse mode in order to create a cardioid pattern, in order to obtain the maximum cancellation on the stage, and a precise and steady sound towards the audience.



KSON CountryFest

Petco Park, San Diego CA
28/10/2018



EQUIPMENT USED

- 24 VIO L212
- 14 VIO L210
- 22 VIO S218

The KSON CountryFest, a sold-out Sunday concert with five bands on a stage set up entirely with dBTechnologies, was the first show in the US to feature the VIO L212, and featured James Barker Band, Maddie and Tae, Midland, Uncle Kracker and Brett Young. The system onstage was made up of 12 VIO L212 boxes per side, VIO L210 boxes as side and front fills, LVX XM monitors and VIO S218 subs.



Atlantico Live!

Indoor installation, Rome IT
14/11/2019



EQUIPMENT USED

- 18 VIO L212
- 8 VIO L210
- 16 VIO S218

With a total capacity of 3,000, Atlantico Live! is a highly valued and unique location in Italy, thanks its ability to combine the rock charm of a traditional concert space with the functionality of a large and multifunctional venue. The venue is a dynamic and versatile place able to host events, happenings and performances of many of the most famous national and international artists. The acoustic project, designed to exploit the potential and features of VIO L212, provides 9x VIO L212 per side and 16x VIO S218, with VIO L210 as a frontfill.



Ostrich Festival 2019

Tumbleweed Park, Chandler AZ
08/03/2019 - 10/03/2019



EQUIPMENT USED

- 16 VIO L212
- 6 VIO L210
- 10 VIO S218

The Chandler Ostrich Festival came to 31st edition and gathered hundreds and hundreds of people to attend three days of pure music and entertainment. VIO L212 was chosen to power the immense Tumbleweed Park at Chandler. This year the line-up included the live performances of the famous rapper Flo Rida, The Commodores and Andy Grammer that attracted a huge audience and enthusiastic. The PA involved 16 VIO L212, 10 S218, 4 VIO S318, 4 VIO L210 as front fill, 2 VIO S318 and 2 VIO L210 as side fill.



REFERENCES

ADAC Supercross

Westfahlenhallen, Dortmund DE
11/01/2019 - 13/01/2019



EQUIPMENT USED

64 VIO L212
20 VIO L208

A dBTechnologies PA to power the 36th annual ADAC Supercross held at Westfahlenhallen in Dortmund, Germany. The PA chosen for the event involved the full-scale line array systems VIO L212 and VIO L208. The ADAC Supercross is the most famous and traditional supercross event held in Germany, involving more than 10,000 people for each of the three days of competition. The 360-degree sound system was implemented with 8 clusters in the middle of the venue: 64 VIO L212, 20 VIO L208 as under balcony speakers.



REFERENCES

69th Sanremo Italian Song Festival

Teatro Ariston, Sanremo IT
05/02/2019 - 09/02/2019



EQUIPMENT USED

41 VIO L210
8 VIO S118

VIO L210 and VIO S118 are the systems chosen to power the Ariston Theatre in Sanremo, which hosted the most important news and celebrities on the national and international scene. The main PA consisted of: 16 VIO L210 (8 per side), 3 VIO L210 (hanging in the middle) and 6 VIO S118 (3 per side) in cardioid configuration. Gallery: 16 VIO L210 (8 per side) and 2 VIO S118 (1 per side), delay under gallery: 4 VIO L210 (2 per side), central gallery (on truss): 2 VIO L210.



PARIS BATTLE PRO 2019

La Seine Musicale, Paris FR
23/02/2019



EQUIPMENT USED

32 VIO L212
10 VIO L210
24 VIO S218

VIO L212 powered the prestigious auditorium of La Seine Musicale, an avant-garde venue located in Paris on the occasion of the World Hip-Hop Dance Championship 2019 with an attendance of about 6,000 spectators. The PA consisted of VIO L212, VIO L210 used as reinforcement in front fill and side fill and the VIO S218 subwoofer, in the following configuration: 32 VIO L212 (16 per side in two clusters), 8 VIO L210 as front fill, 2 VIO L210 in ground stack as side fill 24 VIO S218 in ground stack in hybrid arc delay configuration.



Keimyung University Festival with Psy

Daegu, South Korea
24/05/2017



EQUIPMENT USED

24 VIO L210
6 VIO S318

On May 2017, for Keimyung University Spring Festival dBTechnologies was chosen to power PSY show. More than 10,000 people enjoyed his performance and his music thanks to the PA, consisting in 24 VIO L210 and 6 S318.



REFERENCES

Malika Ayane - Domino Tour

Multiple theaters, Italy
04/11/2018 - 23/02/2019



EQUIPMENT USED

- 24 VIO L208
- 15 VIO S118R

VIO L208 was the main PA for Domino Tour 2018, the new project of Malika Ayane, singer and songwriter amongst the most refined and loved performers of the Italian scenario. The configuration has been adapted to the dimensions and characteristics of the different venues of the indoor tour, some of the most famous Italian theaters. Normally it was 20 VIO L208 (10 per side) with 15 S118R in cardioid configuration and 3 VIO L208 used as front fill.

Paolo Conte Concert

Europa Auditorium, Bologna IT
10/12/2018 - 11/12/2018



EQUIPMENT USED

- 28 VIO L208
- 12 VIO S118R

The great Paolo Conte performed in Bologna with two completely sold-out shows. In a crowded Europa Auditorium Theatre, dBTechnologies has ensured an optimal public sound reinforcement thanks to the versatility of VIO L208. The acoustic project was carefully considered on the structural peculiarities of the venue, which has two raised levels, a very large audience and an impressive stage developed in depth, that framing the performance space. The PA involved 24 VIO L208, 12 S118R and 4 VIO L208 as front fill.

Find all products datasheets on

www.dbtechnologies.com

Features, specification and appearance of products are subject to change without notice. dBTechnologies reserves the right to make changes or improvements in design or manufacturing without assuming any obligation to change or improve products previously manufactured.

SMARTER LIGHTER FASTER STRONGER



HEADQUARTERS

AEB Industriale s.r.l.
Via Brodolini, 8 Loc. Crespellano
40053 Valsamoggia (BO)
Tel.: +39 051 96 98 70
Email: info@dbtechnologies-aeb.com

US OFFICES

dBTech USA
407 Lincoln Road, Suite 4E
Miami Beach FL 33139
Tel.: +786 542-5034
Email: contact@dbtechusa.com

CENTRAL EUROPE OFFICES

dBTechnologies Deutschland
Ettore-Bugatti-Strasse 5
D-51149 Köln
Tel.: +49 2203 947 15-0
Email: info@dbtechnologies.de